



PRODUCT PRICE LIST JUNE 2022



 **SPARES WEBSTORE**
Purchase Blue Seal Spares directly online
spares.blue-seal.co.uk

SPARES - 0121 322 6646
SERVICE - 0121 322 6647



New customers get 10% off first order

BLUE SEAL EVOLUTION SERIES®

Cobra®

turbofan®

VEERAY®

Fastfri.

Contact Details

Sales Office: T. 0121-327-5575 F. 0121-327-9711
Spares: T. 0121-322-6640 / 0121-322-6641, F. 0121-327-9201
Service: T: 0121-322-6644, F. 0121-327-6257
Operating Hours: Mon-Thurs 8.45-4.45. Friday 8.45-4.15.

David Chesshire, National Accounts Manager 07764-663174
Philip Basson, Sales Manager 07764-663175
Donald Harvey, Sales Manager 07764-663176

Test Kitchen & Technical Support

Our fully equipped on-site test kitchen offers prospective customers the opportunity to experience the Blue Seal product range first hand in a commercial cooking environment. Product demonstrations are available on request and are conducted by experienced and knowledgeable personnel.

Our experienced and highly skilled technical support staff and a network of over 200 field service engineers provide excellent support to customers throughout the UK.

Distribution & Delivery Options

Our central distribution hub is based at our Headquarters in Birmingham, close to the country's major motorway network, ideally placed for next day deliveries to most parts of the UK. Most models and spares are available ex-stock.

Units (Applicable UK Mainland Deliveries ONLY)

Delivery in four days – free of charge
Next day up to 5pm – £55.00
Next day before 12 noon – £70.00
Next day timed – £90.00

You are strongly advised not to book any installation engineers until you have received delivery and have inspected the goods. Blue Seal will not be held liable for any cost incurred due to late delivery or damage.

Spares

UK mainland £10.00 per consignment (FOC for orders over £50.00)
Ireland, Channel Islands and Isle of Man £20.00 per consignment
Northern Ireland £20.00 per consignment
To guarantee next day delivery – orders must be received by 3.00pm. Next day deliveries to the Scottish Highlands cannot be guaranteed.

Product Information

CD product range catalogues, Cad library and high quality product images are available to specifiers, dealers and end users on request or on our website at www.blue-seal.co.uk.

Spares

We understand the importance of an accurate spares identification, ordering and fast turnaround facility and that's why we've created a dedicated spares section on our website.

You'll find expandable technical drawings of every unit in our range, plus complimentary lists of the relevant spares complete with full description and part numbers.
www.blue-seal.co.uk



Over 300 catering





HEAVY DUTY EQUIPMENT



NEW PRODUCTS



MISCELLANEOUS



MEDIUM DUTY EQUIPMENT

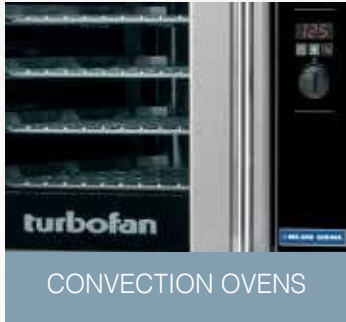

CONVECTION OVENS



PIZZA & BAKERY EQUIPMENT



COMBINATION STEAMERS



WARE WASHING

equipment products for every kind of catering location

BLUE SEAL EVOLUTION

- Heavy Duty Modular Equipment
- New Products 4 - 5
- Miscellaneous 6 - 7
- Gas Cooktops 8 - 11
- Electric Cooktops 12 - 15
- Induction Cooktops 16
- Gas Oven Ranges 17 - 22
- Gas Target Tops & Oven Ranges . 23 - 24
- Electric Oven Ranges 25
- Gas Tilting Bratt Pans 26
- Electric Tilting Bratt Pans 27
- Gas Griddles 28 - 31
- Electric Griddles 32 - 35
- Gas Griddle Ovens 36 - 37
- Gas Griddle Toaster 37
- Electric Griddle Ovens 38
- Gas Chargrills 39 - 40
- Gas & Electric Salamanders 42
- Gas Fryers 43 - 44
- Electric Fryers 45
- Fryer Filters 46
- Pasta Cookers 47
- In-Fill Tables 48
- Optional Extras 49 - 50

Cobra®

- Medium Duty Modular Equipment. 51 - 59

turbofan®

- High Speed Convection Ovens . . . 60 - 66
- Bake-Off Ovens, Provers 67 - 68 & Holding Cabinets
- Ventless Hoods 69

BLUE SEAL®

- Combination Steamers 70 - 72
- Pizza Ovens & Mixers 73
- Ware Washing Equipment 74 - 75

Model	Hob Options	Dimensions	Gas Power kW	Price (exc. VAT)
-------	-------------	------------	--------------	------------------

900mm GAS BBQ | OPEN CABINET BASE



CB9

CB9
900mm BBQ, Mounted
On Open Cabinet Base

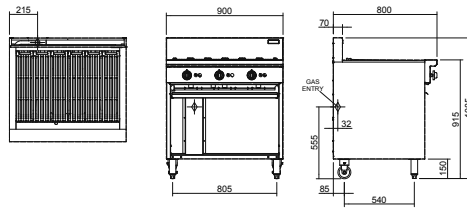

29.4

£2,840.00

450mm | SINGLE PAN GAS PASTA COOKER



CP4

W 450mm x D 800mm x H 915mm

- High performance single pan pasta cooker
- Patented infra-red burner system
- Easy clean 316 grade stainless steel open pan
- 40L water capacity
- Integrated water fill and starch skimming water faucet
- Six stainless steel pasta baskets supplied
- Hinged basket drain stand
- Safety cut-out thermostat for empty pan/water boil out
- Stainless steel exterior
- Easy clean
- Easy service
- Fully modular

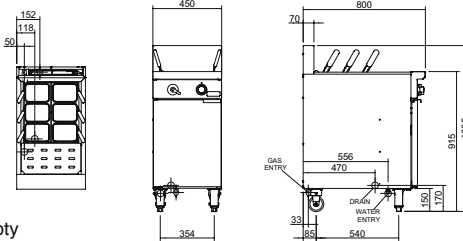

13

£4,415.00

240516 Noodle basket kit

£320.00

600mm | SALAMANDER BENCH



To suit QSET60/QSE60 rise and fall salamanders.

B60S-L Leg stand

£1,790.00

B60S-CB Cabinet base

£1,900.00

Model	Hob Options	Dimensions	Gas Power kW	Price (exc. VAT)
-------	-------------	------------	--------------	------------------



H8D-UC

H8D-UC | HOLDING CABINET

- W 610mm x D 680mm x H 810mm
- 8 x 1/1 GN tray capacity
- 74mm tray spacing
- 1.2kW heating power
- Electronic touch sensitive control panel

1.2 £4,440.00



H8D-FS-UC

H8D-FS-UC | HOLDING CABINET

- W 735mm x D 810mm x H 810mm
- 8 full size 460mm x 660mm / 18" x 26" sheet pan capacity
- 74mm tray spacing
- 1.9kW heating power
- Electronic touch sensitive control panel

1.9 £4,555.00



H10D-FS

H10D-FS | HOLDING CABINET

- W 735mm x D 810mm x H 1015mm
- 10 full size 460mm x 660mm / 18" x 26" sheet pan capacity
- 74mm tray spacing
- 1.9kW heating power
- Electronic touch sensitive control panel

1.9 £4,795.00



H10D

H10D | HOLDING CABINET

- W 610mm x D 680mm x H 1015mm
- 10 1/1 GN pan capacity
- 74mm tray spacing
- 1.2kW heating power
- Electronic touch sensitive control panel

1.2 £4,580.00



EHT10-L

EHT10-L | TOUCH SCREEN ELECTRIC HUMIDIFIED HOLDING CABINET

- W 610mm x D 680mm x H 1015mm
- 10 1/1 GN pan capacity
- 2.3kW heating power
- Electronic touch sensitive control panel

2.3 £6,020.00



OPTIONAL EXTRAS

SKEHT10	Stainless steel stand with castors (2 with swivel lock) to suit EHT10-L model W610mm x D 727mm x H 609mm	£625.00	
237472	Double stacking kit to suit E33/EHT10-L models	£205.00	
234347	Filter head kit This kit supplies the cartridge mounting head assembly plus all associated plumbing/fittings for installation to P8/P12/P10/P85 probers. Also includes double check/pressure reducing valve and 2 metres of tubing for connection to supply	£300.00	
234562	Filter Cartridge P124BN CUNO Filter cartridge itself for connection to above installation kit	£235.00	

MISCELLANEOUS

Model	Hob Options	Dimensions	Gas Power kW	Price (exc. VAT)
-------	-------------	------------	--------------	------------------

Fastfri.

FF18 | GAS FRYER 400mm



FF18

400mm wide single pan fryer
Stainless steel finish
18 litre oil capacity
Mechanical thermostat
Manual pilot ignition
30mm drain valve
90MJ multi-jet target burner
25kg / hr production rate

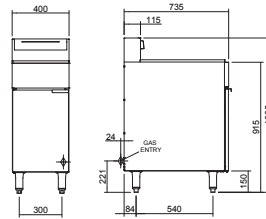

25 £1,655.00

Splash Guards

237307	Left Hand	£95.00
237308	Right Hand	£95.00



G750-6

G750-6 | GAS 6 BURNER RANGE STATIC OVEN



G750-6

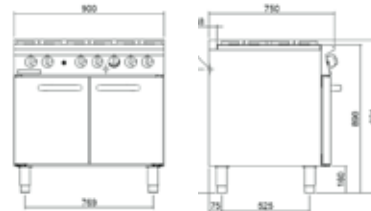

42.7 £2,705.00

Mobile castor kit P/No 238007 (x4 castors)
UKSPSR6 Splash back and over shelf

£125.00
£615.00



QSET60/QSE60

QSET60 | RAPID HEAT RISE & FALL GRILL



QSET60	600mm wide x 450mm deep x 500mm high	4	£3,485.00
QSET60 Plate detector as standard.			
QSE60	600mm wide x 450mm deep x 500mm high	4	£3,235.00
9003	Wall brackets		£175.00

Model	Hob Options	Dimensions	Gas Power kW	Price (exc. VAT)
E83		FOOD WARMER		



E83

W 595mm x D 356mm x H 515mm

1

£900.00

- Temperature display
- Stay-cool door handles
- Easy-clean removable glass doors
- Anti-pilfer door locking clip
- Solid glass back option (no extra cost)
- Plugs into 10A power supply
- Capacity 50 pies
- Rack sizes 4 racks, 493 x 295mm
- Power Supply 220-240V 800W 3.4A
- Shipping Data 19.5kg, 0.16m3 packed

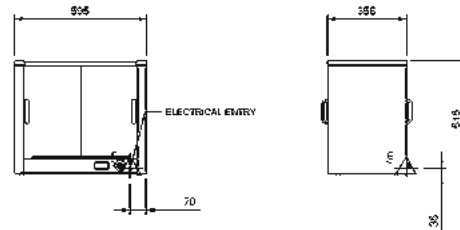

E84

E84		FOOD WARMER		
------------	--	--------------------	--	--

W 795mm x D 356mm x H 515mm

1.5

£985.00

- Thermostat control
- Temperature display
- Stay-cool door handles
- Easy-clean removable glass doors
- Anti-pilfer door locking clip
- Solid glass back option (no extra cost)
- Plugs into 10A power supply
- Capacity 80 – 100 pies
- Rack sizes 4 racks, 693 x 295mm
- Power Supply E84 220-240V 1100W 4.6A
- Shipping Data 25kg, 0.21m3 packed

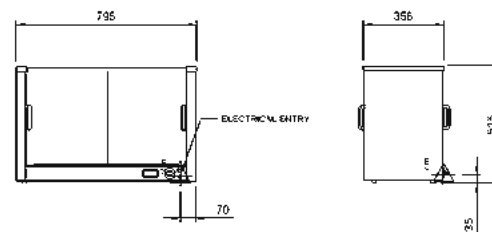

GAS COOKTOPS

Model	Hob Options	Dimensions	Gas Power kW	Price (exc. VAT)
-------	-------------	------------	--------------	------------------



300mm COOKTOPS | BENCH MODEL



G512D-B			14	£1,455.00
G512C-B			6	£1,750.00

G512D-B



600mm | BENCH MODEL



G514D-B			28	£2,715.00
G514C-B			20	£3,015.00
G514B-B			12	£3,290.00

G514D-B



600mm | CABINET BASE



G514D-CB			28	£3,050.00
G514C-CB			20	£3,325.00
G514B-CB			12	£3,610.00

G514D-CB

OPTIONAL	228791	Gastronorm racking kit 1/1 GN / 4 position	£235.00
----------	--------	--	---------



600mm | LEG STAND



G514D-LS			28	£2,890.00
G514C-LS			20	£3,195.00
G514B-LS			12	£3,485.00

G514D-LS

Note: Flame failure standard on open burners. Standard machined finish smooth griddle plate supplied.
 Choice of griddle surfaces: Simply order the optional griddle plate model number and unit is supplied with your nominated surface. View options page 9.

GAS COOKTOPS

Model	Hob Options	Dimensions	Gas Power kW	Price (exc. VAT)
-------	-------------	------------	--------------	------------------



900mm COOKTOPS | BENCH MODEL



G516D-B			42	£3,255.00
G516C-B			34	£3,545.00
G516B-B			26	£3,815.00
G516A-B			18	£4,120.00

G516D-B



900mm | CABINET BASE



G516D-CB			42	£3,965.00
G516C-CB			34	£4,255.00
G516B-CB			26	£4,535.00
G516A-CB			18	£4,820.00

G516D-CB

OPTIONAL 228791 Gastronorm racking kit 1/1 GN / 4 position / 900mm Cabinet Base £235.00
Accommodates 1 or 2 Racking Kits



900mm | LEG STAND



G516D-LS			42	£3,475.00
G516C-LS			34	£3,740.00
G516B-LS			26	£4,035.00
G516A-LS			18	£4,305.00

G516C-LS



900mm | REFRIGERATED BASE, 2 x 1/1 GN DRAWERS



G516D-RB			42	£7,545.00
G516C-RB			34	£7,825.00
G516B-RB			26	£8,105.00
G516A-RB			18	£8,405.00

G516D-RB

Note: Flame failure standard on open burners. Standard machined finish smooth griddle plate supplied.

Choice of griddle surfaces: Simply order the optional griddle plate model number and unit is supplied with your nominated surface. View options page 9.

GAS COOKTOPS

Model	Hob Options	Dimensions	Gas Power kW	Price (exc. VAT)
-------	-------------	------------	--------------	------------------

1200mm COOKTOPS | BENCH MODEL



G518D-B			56	£3,965.00
G518C-B			48	£4,255.00
G518B-B			40	£4,535.00
G518A-B			32	£4,820.00

G518B



G518C-B

1200mm | CABINET BASE (RACKING KIT NOT INCLUDED)



G518D-CB			56	£4,670.00
G518C-CB			48	£4,960.00
G518B-CB			40	£5,255.00
G518A-CB			32	£5,525.00

OPTIONAL

228791 Gastronorm racking kit fits 1/1 GN or 2/1 GN / 4 position / 1200mm Cabinet Base. Accommodates 1 or 2 Racking Kits

£235.00

1200mm | LEG STAND



G518D-LS			56	£4,305.00
G518C-LS			48	£4,625.00
G518B-LS			40	£4,900.00
G518A-LS			32	£5,185.00

G518-LS

1200mm | REFRIG. BASE, 2x1/1 GN DRAWERS / 1x1/1 GN DOOR



G518D-RB			56	£8,595.00
G518C-RB			48	£8,895.00
G518B-RB			40	£9,170.00
G518A-RB			32	£9,460.00

Note: Flame failure standard on open burners. Standard machined finish smooth griddle plate supplied.

Choice of griddle surfaces: Simply order the optional griddle plate model number and unit is supplied with your nominated surface. View options page 9.

Model	Description	Price (exc. VAT)
300mm OPTIONAL GRIDDLE PLATE SURFACE		
PG312R3*	300mm x 12mm Griddle plate – ribbed full	£985.00

600mm OPTIONAL GRIDDLE PLATE SURFACE		
PG612R3*	600mm x 12mm Griddle plate – ribbed 300mm RH	£1,140.00
PG612R6*	600mm x 12mm Griddle plate – ribbed full	£1,515.00

900mm OPTIONAL GRIDDLE PLATE SURFACE		
PG912R3*	900mm x 12mm Griddle plate – ribbed 300mm RH	£1,255.00
PG912R5*	900mm x 12mm Griddle plate – ribbed 450mm RH	£1,610.00
PG912R9*	900mm x 12mm Griddle plate – ribbed full	£2,510.00

900mm OPTIONAL GRIDDLE PLATE SURFACE FOR 1200mm WIDE HOBS		
PG912R3*	900mm x 12mm Griddle plate – ribbed 300mm RH	£1,255.00
PG912R5*	900mm x 12mm Griddle plate – ribbed 450mm RH	£1,610.00
PG912R9*	900mm x 12mm Griddle plate – ribbed full	£2,510.00

OPTIONAL EXTRAS GAS COOKTOPS

228807	Mobile castor kit (set of 2 lockable)	£120.00
Flex3/4/51	Flexihose 3/4 (flexible quick coupling hose & tether chain)	£225.00
230013	Bench shield, fits LH or RH of open burners	£110.00

Note: The standard plate is not included when ordering an optional griddle plate surface.

*Options must be specified at the placement of order.

ELECTRIC COOKTOPS

Model	Hob Options	Dimensions	Price (exc. VAT)
-------	-------------	------------	------------------



300mm COOKTOPS

BENCH MODEL

E512D-B
Electrical requirements:
 4.8kW, 230-240Vac,
 50/60Hz, 1P+N+E, 20A

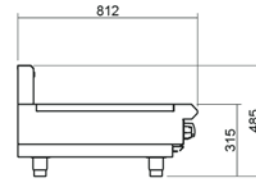

£1,530.00

E512C-B
Electrical requirements:
 3.4kW, 230-240Vac,
 50/60Hz, 1P+N+E, 14.2A



£1,820.00

E512C -B



600mm COOKTOPS

BENCH MODEL

E514D-B
Electrical requirements:
 9.6kW, 400-415Vac,
 50/60Hz, 2P+N+E, 20A

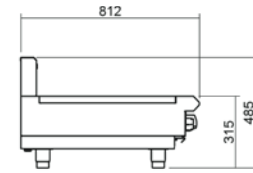
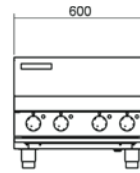

£3,255.00

E514C-B
Electrical requirements:
 8.2kW, 400-415Vac,
 50/60Hz, 2P+N+E, 20A



£3,545.00

E514B-B
Electrical requirements:
 6.8kW, 230-240Vac,
 50/60Hz, 1P+N+E, 30A



£3,835.00

E514C-B



600mm

CABINET BASE (RACKING KIT NOT INCLUDED)

E514D-CB
Electrical requirements:
 9.6kW, 400-415Vac,
 50/60Hz, 2P+N+E, 20A

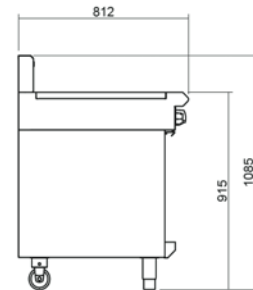
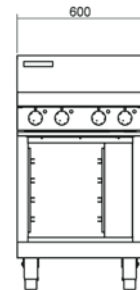

£3,475.00

E514C-CB
Electrical requirements:
 8.2kW, 400-415Vac,
 50/60Hz, 2P+N+E, 20A



£3,755.00

E514B-CB
Electrical requirements:
 6.8kW, 230-240Vac,
 50/60Hz, 1P+N+E, 30A



£4,035.00

E514D-CB

OPTIONAL

228791













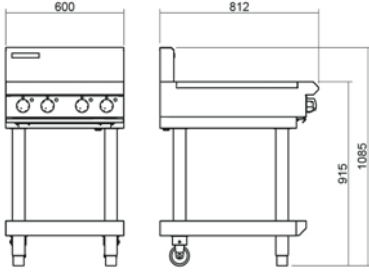

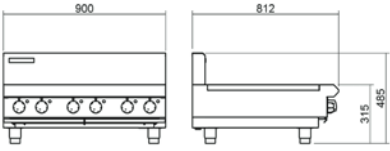

Gastronorm racking kit 1/1 GN / 4 position

£235.00

Note: Standard machined finish smooth griddle plate supplied.

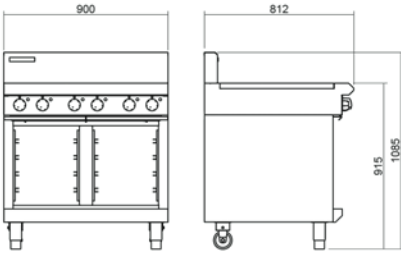
Choice of griddle surfaces: Simply order the optional griddle plate model number and unit is supplied with your nominated surface. View options page 13.

ELECTRIC COOKTOPS

Model	Hob Options	Dimensions	Price (exc. VAT)
600mm COOKTOPS		LEG STAND	
			£3,415.00
E514D-LS Electrical requirements: 9.6kW, 400-415Vac, 50/60Hz, 2P+N+E, 20A			£3,695.00
E514C-LS Electrical requirements: 8.2kW, 400-415Vac, 50/60Hz, 2P+N+E, 20A			£3,975.00
E514B-LS Electrical requirements: 6.8kW, 230-240Vac, 50/60Hz, 1P+N+E, 30A			
900mm COOKTOPS		BENCH MODEL	
			£4,610.00
E516D-B Electrical requirements: 14.4kW, 400-415Vac, 50/60Hz, 3P+N+E, 20A			£4,900.00
E516C-B Electrical requirements: 13kW, 400-415Vac, 50/60Hz, 3P+N+E, 20A			£5,175.00
E516B-B Electrical requirements: 11.6kW, 400-415Vac, 50/60Hz, 3P+N+E, 20A			£5,465.00
E516A-B Electrical requirements: 10.2kW, 400-415Vac, 50/60Hz, 3P+N+E, 15A			
900mm		CABINET BASE (RACKING KIT NOT INCLUDED)	
			£5,025.00
E516D-CB Electrical requirements: 14.4kW, 400-415Vac, 50/60Hz, 3P+N+E, 20A			£5,330.00
E516C-CB Electrical requirements: 13kW, 400-415Vac, 50/60Hz, 3P+N+E, 20A			£5,605.00
E516B-CB Electrical requirements: 11.6kW, 400-415Vac, 50/60Hz, 3P+N+E, 20A			£5,890.00
E516A-CB Electrical requirements: 10.2kW, 400-415Vac, 50/60Hz, 3P+N+E, 15A			
OPTIONAL	228791	Gastronorm racking kit 1/1 GN / 4 position / 900mm Cabinet Base Accommodates 1 or 2 racking kits	£235.00

E514D-LS

E516D-B

E516D-CB

Note: Standard machined finish smooth griddle plate supplied.

Choice of griddle surfaces: Simply order the optional griddle plate model number and unit is supplied with your nominated surface. View options page 13.

ELECTRIC COOKTOPS

Model	Hob Options	Dimensions	Price (exc. VAT)
-------	-------------	------------	------------------



900mm COOKTOPS | LEG STAND

E516D-LS Electrical requirements: 14.4kW, 400-415Vac, 50/60Hz, 3P+N+E, 20A			£4,900.00
E516C-LS Electrical requirements: 13kW, 400-415Vac, 50/60Hz, 3P+N+E, 20A			£5,175.00
E516B-LS Electrical requirements: 11.6kW, 400-415Vac, 50/60Hz, 3P+N+E, 20A			£5,465.00
E516A-LS Electrical requirements: 10.2kW, 400-415Vac, 50/60Hz, 3P+N+E, 15A			£5,750.00

E516B-LS

900mm | REFRIGERATED BASE, 2 x 1/1 GN DRAWERS

E516D-RB Electrical requirements: 14.4kW, 400-415Vac, 50/60Hz, 3P+N+E, 20A			£7,035.00
E516C-RB Electrical requirements: 13kW, 400-415Vac, 50/60Hz, 3P+N+E, 20A			£7,305.00
E516B-RB Electrical requirements: 11.6kW, 400-415Vac, 50/60Hz, 3P+N+E, 20A			£7,605.00
E516A-RB Electrical requirements: 10.2kW, 400-415Vac, 50/60Hz, 3P+N+E, 15A			£7,870.00

Note: Standard machined finish smooth griddle plate supplied.

Choice of griddle surfaces: Simply order the optional griddle plate model number and unit is supplied with your nominated surface. View options page 13.

Model	Description	Price (exc. VAT)
300mm OPTIONAL GRIDDLE PLATE SURFACE		
PE312R3*	300mm x 12mm Griddle plate – ribbed full	£1,040.00

600mm OPTIONAL GRIDDLE PLATE SURFACE		
PE612R3*	600mm x 12mm Griddle plate – ribbed 300mm RH	£1,190.00
PE612R6*	600mm x 12mm Griddle plate – ribbed full	£1,745.00

900mm OPTIONAL GRIDDLE PLATE SURFACE		
PE912R3*	900mm x 12mm Griddle plate – ribbed 300mm RH	£1,590.00
PE912R5*	900mm x 12mm Griddle plate – ribbed 450mm RH	£1,830.00
PE912R9*	900mm x 12mm Griddle plate – ribbed full	£2,650.00

OPTIONAL EXTRAS ELECTRIC COOKTOPS

228807	Mobile castor kit (2 lockable)	£120.00
013600	Solid cast element	£260.00

Note: The standard plate is not included when ordering an optional griddle plate surface.
*Options must be specified at the placement of order.

INDUCTION COOKTOPS



- High performance 450mm and 900mm Induction Cooktops
- 6mm thick ceramic glass cooking surface with Cabinet Base
- Fully modular with adjustable feet for match suite finish
- Two/Four 270mm diameter induction zones
- Infinitely variable power controls for each induction zone
- Automatic pan detection switches cooking zone off when a pan is removed
- Heating ON indicator lights (green) including pan detection indication
- Fully sealed cooking surface
- Removable full stainless steel air intake filters (induction cooling)
- Front service access

Model	Dimensions	Price (exc. VAT)
-------	------------	------------------

450mm 2 ZONE INDUCTION COOKTOP | CABINET BASE



IN512-CB
2 x 5kW induction plates
Ø 270mm cooking zones

Electrical requirements:
IN512-CB
10kW, 400-415Vac, 50/60hz, 3P+E
16A/phase

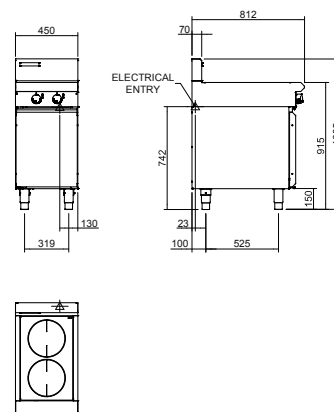

£10,020.00

IN512-CB

900mm 4 ZONE INDUCTION COOKTOP | CABINET BASE



IN514-CB
4 x 5kW induction plates
Ø 270mm cooking zones

Electrical requirements
IN514-CB
20kW, 400-415Vac, 50/60hz, 3P+E
32A/phase

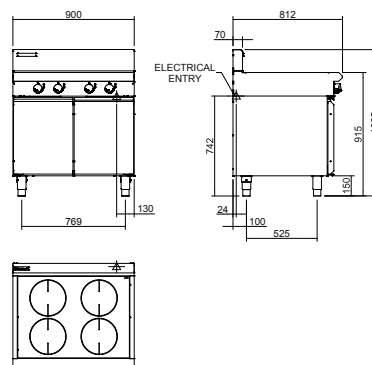

£16,340.00

IN514-CB

BLUE SEAL EVOLUTION SERIES®

Whatever the scale of operation, Blue Seal Evolution Series Oven Ranges have a gas or electric option to suit. Gas options come equipped with our 7kW open cooktop burners, while the electric versions offer a choice of heavy-duty 2.4kW radiant elements, or 2kW solid plates.

Within the oven itself, cast iron sole plates ensure even heat distribution. Heavy-duty motors and circulation fans in the convection ovens reduce cooking times and enable food to be cooked at Lower temperatures.

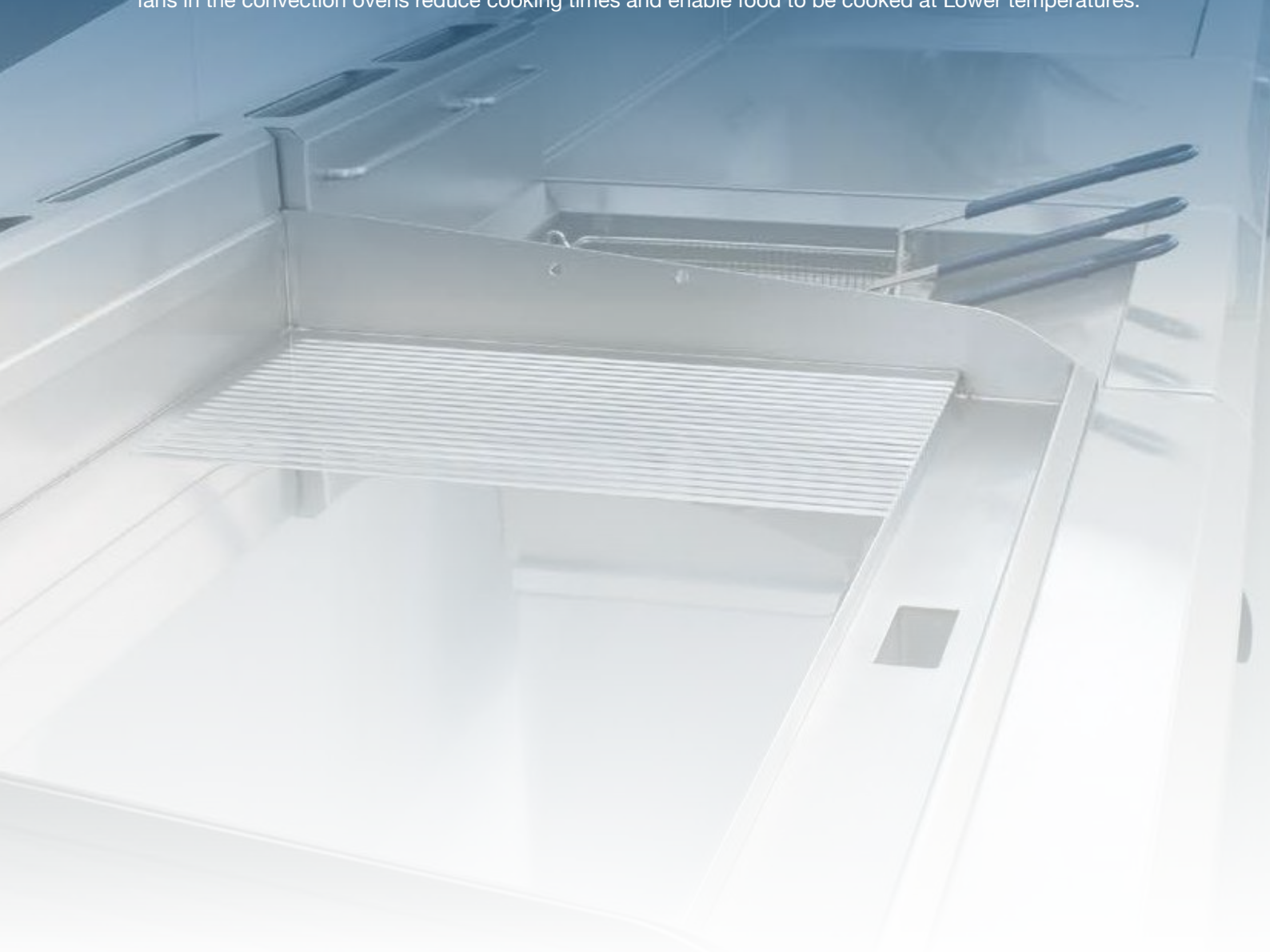

Refrigerated Units - Chill where you cook. The inclusion of refrigeration units into the cooking line means raw materials can be safely stored nearby.

Ease of cleaning - The 3mm splashguard is a fully welded hob surround providing extra durability and ease of cleaning













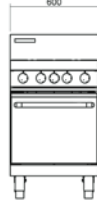

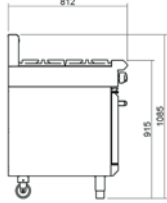

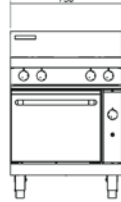

Accurate Temperature Control - Heavy-duty control knobs with strengthened shafts are designed to last. Non-fade temperature markings provide accurate heat settings for more consistent results.

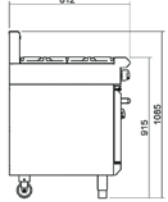
Target Tops - Delivering power where you need it. Heat is delivered by a 12.5kW dual ring, cast iron burner, with single control.

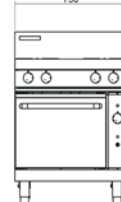

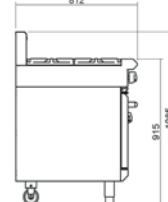
It's all about power, performance and choice.

GAS OVEN RANGES

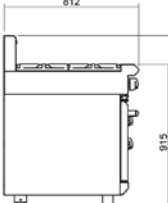
Model	Hob Options	Dimensions	Gas Power kW	Price (exc. VAT)
		600mm GAS RANGE	STATIC OVEN - 1/1 GN	
			37.7	£3,340.00
			27.8	£3,620.00
			17.8	£3,930.00
G504D				
		750mm GAS RANGE	STATIC OVEN - 1/1	
			37	£3,665.00
			29	£3,955.00
G505D				
		750mm GAS RANGE	CONVECTION OVEN - 1/1	
			37	£5,765.00
			29	£6,045.00
G54C				
		Electrical requirements: 0.13kW, 230-240Vac, 50/60Hz, 1P+N+E, 0.6A 3 PIN, 13A Cordset fitted		
		750mm GAS RANGE	ELECTRIC STATIC OVEN - 1/1 GN	
			28	£5,410.00
			20	£5,700.00
GE505D				
		Electrical requirements: 5.5kW, 230-240Vac, 50/60Hz, 1P+N+E, 23A standard or 5.5kW, 400-415Vac, 50/60Hz, 3P+N+E, 8A		

Note: Flame failure standard on open burners. Standard machined finish smooth griddle plate supplied.
Choice of griddle surfaces: Simply order the optional griddle plate model number and unit is supplied with your nominated surface. View options page 22.

GAS OVEN RANGES

Model	Hob Options	Dimensions	Gas Power kW	Price (exc. VAT)
-------	-------------	------------	--------------	------------------



GE54D

750mm GAS RANGE | ELECTRIC CONVECTION OVEN - 1/1 GN

GE54D



GE54C



Electrical requirements:

5.6kW, 230-240Vac,
50/60Hz, 1P+N+E, 23.3A
standard or 5.6kW, 400-415Vac,
50/60Hz, 3P+N+E, 8A

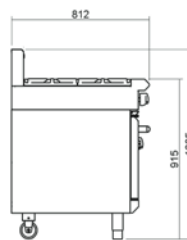
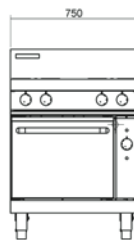

28

£6,455.00







20

£6,765.00



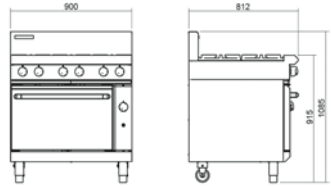







Note: Flame failure standard on open burners. Standard machined finish smooth griddle plate supplied.
Choice of griddle surfaces: Simply order the optional griddle plate model number and unit is supplied with your nominated surface. View options page 22.

GAS OVEN RANGES

Model	Hob Options	Dimensions	Gas Power kW	Price (exc. VAT)
		900mm GAS RANGE STATIC OVEN - 2/1 GN		 
G506D			51	£3,590.00
G506C			43	£3,885.00
G506B			35	£4,170.00
G506A			27	£4,450.00

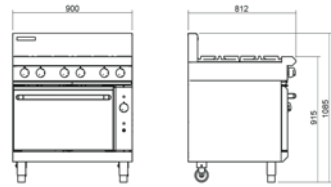









G506D

		900mm GAS RANGE CONVECTION OVEN - 2/1		  
G56D			51	£7,000.00
G56C			43	£7,270.00
G56B			35	£7,555.00
G56A			27	£7,845.00
Electrical requirements:				
0.13kW, 230-240Vac, 50/60Hz, 1P+N+E, 0.6A 3 PIN, 13A Cordset fitted				

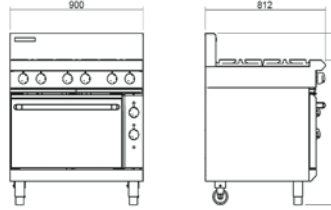









G56D

		900mm GAS RANGE ELECTRIC STATIC OVEN - 2/1		  
GE506D			42	£5,845.00
GE506C			34	£6,130.00
GE506B			26	£6,410.00
GE506A			18	£6,690.00
Electrical requirements:				
Standard Supply 6.5kW, 230-240Vac, 50/60Hz, 1P+N+E, 27A standard or 6.5kW, 400-415Vac, 50/60Hz, 3P+N+E, 10A				

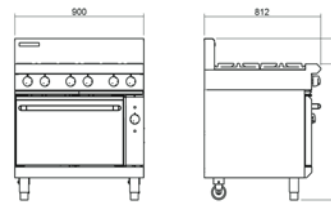

GE506D

		900mm GAS RANGE ELECTRIC CONVECTION OVEN - 2/1GN		  
GE56D			42	£8,605.00
GE56C			34	£8,910.00
GE56B			26	£9,185.00
GE56A			18	£9,480.00
Electrical requirements:				
Standard Supply 6.6kW, 230-240Vac, 50/60Hz, 1P+N+E, 27.7A standard or 6.6kW, 400-415Vac, 50/60Hz, 3P+N+E, 10A				



GE56D

Note: Flame failure standard on open burners. Standard machined finish smooth griddle plate supplied.

Choice of griddle surfaces: Simply order the optional griddle plate model number and unit is supplied with your nominated surface. View options page 22.

GAS OVEN RANGES

Model	Hob Options	Dimensions	Gas Power kW	Price (exc. VAT)
-------	-------------	------------	--------------	------------------



G508D

1200mm GAS RANGE | STATIC OVEN - 2/1 GN



G508D			65	£5,925.00
G508C			57	£6,210.00
G508B			49	£6,485.00
G508A			41	£6,785.00



G58D

1200mm GAS RANGE | CONVECTION OVEN - 2/1



G58D			65	£8,440.00
G58C			57	£8,710.00
G58B			49	£9,005.00
G58A			41	£9,290.00

Electrical requirements::

0.13kW, 230-240Vac,
50/60Hz, 1P+N+E, 0.6A
3 PIN, 13A Cordset fitted



GE508D

1200mm GAS RANGE | ELECTRIC STATIC OVEN - 2/1



GE508D			56	£6,905.00
GE508C			48	£7,190.00
GE508B			40	£7,490.00
GE508A			24	£7,765.00

Electrical requirements:

Standard Supply
6.5kW, 230-240Vac,
50/60Hz, 1P+N+E, 27A standard
or 6.5kW, 400-415Vac, 50/60Hz,
3P+N+E, 10A



GE58D

1200mm GAS RANGE | ELECTRIC CONVECTION OVEN - 2/1 GN



GE58D			56	£9,325.00
GE58C			48	£9,615.00
GE58B			40	£9,905.00
GE58A			24	£10,195.00

Electrical requirements:

Standard Supply
6.6kW, 230-240Vac,
50/60Hz, 1P+N+E, 27.7A standard
or 6.6kW, 400-415Vac, 50/60Hz,
3P+N+E, 10A











Note: Flame failure standard on open burners. Standard machined finish smooth griddle plate supplied.

Choice of griddle surfaces: Simply order the optional griddle plate model number and unit is supplied with your nominated surface. View options page 22.

GAS DOUBLE OVEN RANGES



G528D

Model	Hob Options	Dimensions	Gas Power kW	Price (exc. VAT)
1200mm GAS RANGE		DOUBLE STATIC OVEN - 2 x 1/1 GN		 
G528D			69.2	£7,480.00
G528C			61.2	£7,750.00
G528B			53.2	£8,045.00
G528A			45.2	£8,320.00

Note: Flame failure standard on open burners. Standard machined finish smooth griddle plate supplied.
Choice of griddle surfaces: Simply order the optional griddle plate model number and unit is supplied with your nominated surface. View options below.

GAS OVEN RANGES

Model	Description	Price (exc. VAT)
300mm	OPTIONAL GRIDDLE PLATE SURFACE	
PG312R3*	300mm x 12mm Griddle plate – ribbed full	£985.00
600mm	OPTIONAL GRIDDLE PLATE SURFACES	
PG612R3*	600mm x 12mm Griddle plate – ribbed 300mm RH	£1,140.00
PG612R6*	600mm x 12mm Griddle plate – ribbed full	£1,515.00
900mm	OPTIONAL GRIDDLE PLATE SURFACES	
PG912R3*	900mm x 12mm Griddle plate – ribbed 300mm RH	£1,255.00
PG912R5*	900mm x 12mm Griddle plate – ribbed 450mm RH	£1,610.00
PG912R9*	900mm x 12mm Griddle plate – ribbed full	£2,510.00
900mm	OPTIONAL GRIDDLE PLATE SURFACES FOR 1200mm WIDE HOBS	
PG912R3*	900mm x 12mm Griddle plate – ribbed 300mm RH	£1,255.00
PG912R6*	900mm x 12mm Griddle plate – ribbed 600mm RH	£1,610.00
PG912R9*	900mm x 12mm Griddle plate – ribbed full	£2,510.00

OPTIONAL EXTRAS GAS OVEN RANGES

227896	Oven rack for 900mm ovens	£80.00
228106	Oven rack for 600mm ovens	£75.00
228807	Mobile castor kit (set of 2 lockable)	£120.00
Flex3/4/51	Flexihose 3/4 (flexible quick coupling hose & tether chain)	£225.00
230013	Bench shield, fits LH or RH of open burners	£110.00
UKSP4	Splashback, overshelf for 4 burner ranges	£615.00
UKSP6	Splashback, overshelf and grill shelf for 6 burner ranges	£615.00
UKSP8	Splashback, overshelf for 8 burner range	£615.00

Note: The standard plate is not included when ordering an optional griddle plate surface.
*Options must be specified at the placement of order.

GAS TARGET TOPS

Model	Dimensions	Gas Power kW	Price (exc. VAT)
-------	------------	--------------	------------------



900mm TARGET TOP | BENCH MODEL



G57-B

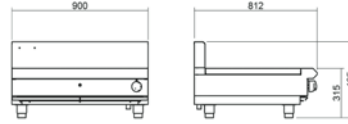

12.5

£3,965.00

G57-B



900mm TARGET TOP | CABINET BASE (RACKING KIT NOT INCLUDED)



G57-CB

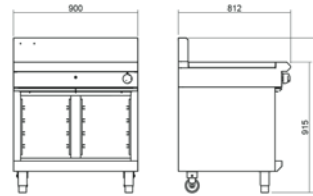

12.5

£4,855.00

G57-CB

OPTIONAL

228791 Gastronorm racking kit 1/1 GN / 4 position / 900mm Cabinet Base £235.00
Accommodates 1 or 2 Racking Kits



900mm TARGET TOP | LEG STAND



G57-LS

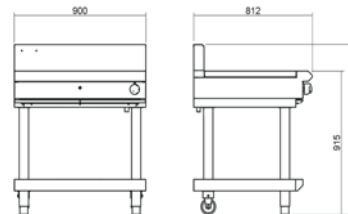

12.5

£4,305.00

G57-LS



900mm TARGET TOP | REFRIGERATED BASE, 2 x 1/1 GN DRAWERS



G57-RB

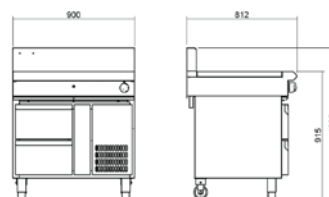

12.5













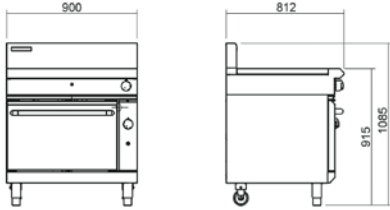

£8,605.00

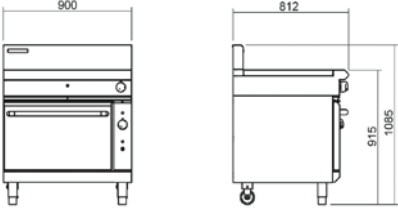
G57-RB

(RB) ELECTRICAL REQUIREMENT

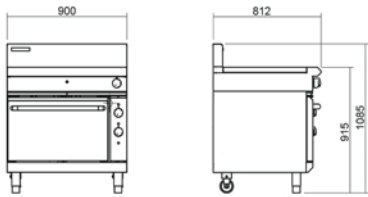
0.5kW, 220-240Vac, 50Hz, 1P+N+E, 1.8A 3 PIN,
13A Cordset fitted

GAS TARGET TOP OVEN RANGES

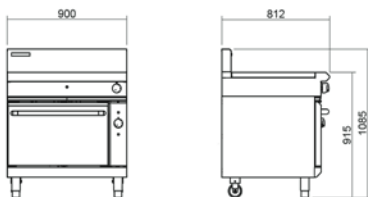
Model	Dimensions	Gas Power kW	Price (exc. VAT)
900mm GAS TARGET TOP STATIC OVEN RANGE – 2/1 GN  			
 G570		21.5	£5,525.00
900mm GAS TARGET TOP CONVECTION OVEN RANGE – 2/1 GN   			
 G576		21.5	£7,260.00
Electrical requirements: 0.13kW, 230-240Vac, 50/60Hz, 1P+N+E, 0.6A 3 PIN, 13A Cordset fitted			
900mm GAS TARGET TOP ELECTRIC STATIC OVEN RANGE – 2/1 GN   			
 GE570		12.5	£5,765.00
Electrical requirements: 6.5kW, 230-240Vac, 50/60Hz, 1P+N+E, 27A standard or 6.5kW, 400-415Vac, 50/60Hz, 3P+N+E, 10A			
900mm GAS TARGET TOP ELECTRIC CONVECTION OVEN RANGE – 2/1 GN   			
 GE576		12.5	£7,430.00
Electrical requirements: 6.5kW, 230-240Vac, 50/60Hz, 1P+N+E, 27A standard or 6.5kW, 400-415Vac, 50/60Hz, 3P+N+E, 10A			

OPTIONAL EXTRAS

GAS TARGET TOPS / OVEN RANGES

227896	Oven rack to suit all 6 burner oven ranges	£80.00
014997	Casting Hook	£65.00
228807	Mobile castor kit (set of 2 lockable)	£120.00
Flex3/4/51	Flexihose 3/4 (flexible quick coupling hose & tether chain)	£225.00

*Options must be specified at the placement of order.

ELECTRIC OVEN RANGES

Model	Hob Options	Dimensions	Price (exc. VAT)
-------	-------------	------------	------------------



E506D

900mm ELECTRIC RANGE | STATIC OVEN - 2/1 GN



E506D Electrical requirements: 20.9kW, 400-415Vac, 50/60Hz, 3P+N+E				£5,550.00
E506C Electrical requirements: 19.5kW, 400-415Vac, 50/60Hz, 3P+N+E				£5,845.00
E506B Electrical requirements: 18.1kW, 400-415Vac, 50/60Hz, 3P+N+E				£6,130.00
E506A Electrical requirements: 16.7kW, 400-415Vac, 50/60Hz, 3P+N+E				£6,410.00

900mm ELECTRIC RANGE | CONVECTION OVEN - 2/1 GN



E56D

E56D Electrical requirements: 21.0kW, 400-415Vac, 50/60Hz, 3P+N+E				£6,925.00
E56C Electrical requirements: 19.6kW, 400-415Vac, 50/60Hz, 3P+N+E				£7,235.00
E56B Electrical requirements: 18.2kW, 400-415Vac, 50/60Hz, 3P+N+E				£7,520.00
E56A Electrical requirements: 16.8kW, 400-415Vac, 50/60Hz, 3P+N+E				£7,795.00

900mm | OPTIONAL GRIDDLE PLATE SURFACES

PE912R3*	900mm x 12mm Griddle plate – ribbed 300mm RH	£1,590.00
PE912R5*	900mm x 12mm Griddle plate – ribbed 450mm RH	£1,830.00
PE912R9*	900mm x 12mm Griddle plate – ribbed full	£2,650.00

OPTIONAL EXTRAS ELECTRIC OVEN RANGES

227896	Oven rack to suit E506D series	£80.00
228807	Mobile castor kit (2 lockable)	£120.00
013600	Solid cast element	£260.00

Note: The standard plate is not included when ordering an optional griddle plate surface.
 *Options must be specified at the placement of order.

Note: Standard machined finish smooth griddle plate supplied.

Choice of griddle surfaces: Simply order the optional griddle plate model number and unit is supplied with your nominated surface. View options above.

GAS TILTING BRATT PANS

Model	Dimensions	Gas Power kW	Price (exc. VAT)
-------	------------	--------------	------------------



900mm | GAS TILTING 80 LITRE BRATT PANS



G580-8

80 Litre stainless steel pan
Manually operated tilting mechanism

Electrical requirements:

220-240Vac, 50/60Hz, 1P+N+E, 1A
3 Pin 13A cordset fitted

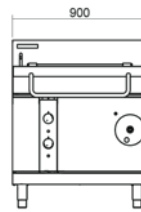

20

£9,875.00

G580-8E

80 Litre stainless steel pan
Electric power tilting mechanism

Electrical requirements:

220-240Vac, 50/60Hz, 1P+N+E, 1A
3 Pin 13A cordset fitted

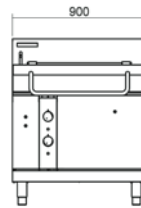

20

£10,625.00

G580-8



1200mm | GAS TILTING 120 LITRE BRATT PANS



G580-12

120 Litre stainless steel pan
Manually operated tilting mechanism

Electrical requirements:

220-240Vac, 50/60Hz, 1P+N+E, 1A
3 Pin 13A cordset fitted

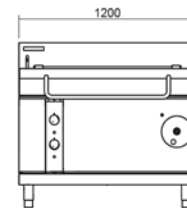

25

£11,780.00

G580-12E

120 Litre stainless steel pan
Electric power tilting mechanism G580-12

Electrical requirements:

220-240Vac, 50/60Hz, 1P+N+E, 1A
3 Pin 13A cordset fitted

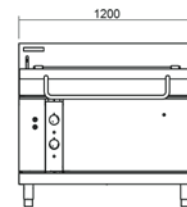

25

£12,500.00

G580-12

OPTIONAL EXTRAS | BLUE SEAL GAS COOKING EQUIPMENT

Flex3/4/51

Flexihose 3/4 (flexible quick coupling hose & tether chain)

£225.00

*Options must be specified at the placement of order.

ELECTRIC TILTING BRATT PANS

Model	Dimensions	Price (exc. VAT)
-------	------------	------------------



900mm | ELECTRIC TILTING 80 LITRE BRATT PANS



E580-8
80 Litre stainless steel pan
Manually operated tilting mechanism

Electrical requirements:
12kW, 400-415Vac, 50/60Hz, 3P+N+E, 17A

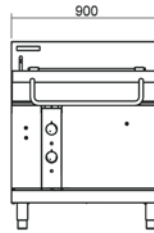

£9,875.00

E580-8E
80 Litre stainless steel pan
Electric power tilting mechanism
E580-8E

Electrical requirements:
12kW, 400-415Vac, 50/60Hz, 3P+N+E, 17A

£10,625.00

E580-8E



1200mm | ELECTRIC TILTING 120 LITRE BRATT PANS



E580-12
120 Litre stainless steel pan
Manually operated tilting mechanism

Electrical requirements:
17kW, 400-415Vac, 50/60Hz, 3P+N+E, 23A

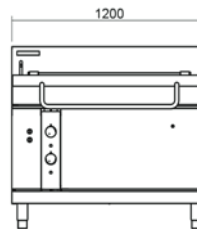

£11,780.00

E580-12E
120 Litre stainless steel pan
Electric power tilting mechanism

Electrical requirements:
17kW, 400-415Vac, 50/60Hz, 3P+N+E, 23A

£12,500.00

E580-12E



EB45D | BAIN-MARIE



W 450mm x D 812mm x H 915mm Incl. heater 1224mm
Heating Elements 1 x 1kW surface mount element
Cold water connection 184mm from right hand side, 555mm from floor
R1/2 (BSP) male
550kPa 80psi maximum water pressure
Nett weight 53kg nett

3kW
13amp

£3,780.00

EB45D

GAS GRIDDLES

Model	Dimensions	Gas Power kW	Price (exc. VAT)
-------	------------	--------------	------------------



GP513-LS

GP513 | GAS GRIDDLE 450mm



		Dimensions: mm (w x d x h)			
450mm gas griddle					
11.5kW thermostatic burner	GP513-B	450 x 812 x 485		11.1	£3,495.00
Top weld sealed plates					
Mirror chromed plate option	GP513-LS	450 x 812 x 1085		11.1	£3,835.00
20mm thick griddle plate					
Heavy-duty thermostatic griddle	GP513-CB	450 x 812 x 1085		11.1	£4,015.00
Full pilot and flame failure with piezo ignition					
2 models of the base unit					
Easy clean, installation and service					

Griddle options please contact Blue Seal



GP514-B

600mm GAS GRIDDLE | BENCH MODEL

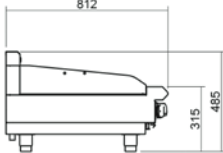

GP514-B			14.5	£3,965.00
----------------	---	--	------	-----------

STANDARD PLATE SUPPLIED | Smooth machined finish mild steel plate PGH620



GP514-CB

600mm GAS GRIDDLE | CABINET BASE (RACKING KIT NOT INCLUDED)

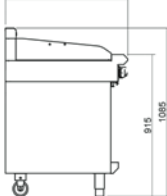

GP514-CB			14.5	£4,485.00
-----------------	---	--	------	-----------

OPTIONAL | 228791 Gastronorm racking kit 1/1 GN / 4 position | £235.00

STANDARD PLATE SUPPLIED | Smooth machined finish mild steel plate PGH620



GP514-LS

600mm GAS GRIDDLE | LEG STAND

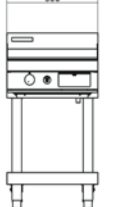
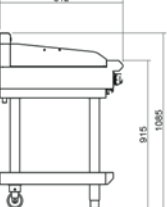

GP514-LS			14.5	£4,305.00
-----------------	---	--	------	-----------

STANDARD PLATE SUPPLIED | Smooth machined finish mild steel plate PGH620

Choice of griddle surfaces: Simply order the optional griddle plate model number and unit is supplied with your nominated surface. View options page 29.
 Note: The standard plate is not included when ordering an optional griddle plate surface.

GAS GRIDDLES

OPTIONAL EXTRAS | 600mm GRIDDLE PLATE SURFACES – CHROMED/RIBBED

PGH620C*	600mm x 20mm Heavy-duty griddle plate – chromed	£1,935.00
PGH620R3*	600mm x 20mm Heavy-duty griddle plate – ribbed 300RH	£2,975.00
PGH620R3C*	600mm x 20mm Heavy-duty griddle plate – ribbed 300RH chromed	£2,275.00
PGH620R6*	600mm x 20mm Heavy-duty griddle plate – ribbed full	£2,205.00
PGH620R6C	600mm x 20mm Heavy-duty griddle plate – ribbed full channel	£2,305.00

*Options must be specified at the placement of order.

PGH420C	£1,870.00
PGH420R5	£2,515.00



900mm GAS GRIDDLE | BENCH MODEL



GP516-B			23	£4,670.00
----------------	---	---	----	-----------

GP516-B

STANDARD PLATE SUPPLIED | Smooth machined finish mild steel plate PGH920



900mm GAS GRIDDLE | CABINET BASE (RACKING KIT NOT INCLUDED)



GP516-CB			23	£5,410.00
-----------------	---	---	----	-----------

GP516-CB

OPTIONAL | 228791 Gastronorm racking kit 1/1 GN / 4 position / 900mm Cabinet Base Accommodates 1 or 2 Racking Kits | £235.00

STANDARD PLATE SUPPLIED | Smooth machined finish mild steel plate PGH920



900mm GAS GRIDDLE | LEG STAND



GP516-LS			23	£5,035.00
-----------------	---	---	----	-----------

GP516-LS

STANDARD PLATE SUPPLIED | Smooth machined finish mild steel plate PGH920

Choice of griddle surfaces: Simply order the optional griddle plate model number and unit is supplied with your nominated surface. View options page 30.

GAS GRIDDLES



GP516-RB

Model	Dimensions	Gas Power kW	Price (exc. VAT)
-------	------------	--------------	------------------

900mm GAS GRIDDLE | REFRIGERATED BASE, 2 x 1/1 GN DRAWERS

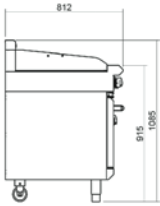
GP516-RB   23 £9,340.00

(RB) Electrical requirements:
0.5kW, 220-240Vac,
50Hz, 1P+N+E, 1.8A,
3 pin 13A plug cordset fitted

STANDARD PLATE SUPPLIED | Smooth machined finish mild steel plate PGH920

OPTIONAL EXTRAS | 900mm GRIDDLE PLATE SURFACES – CHROMED/RIBBED

PGH920C*	900mm x 20mm Heavy-duty griddle plate – chromed	£2,710.00
PGH920R3*	900mm x 20mm Heavy-duty griddle plate – ribbed 300RH	£2,675.00
PGH920R3C*	900mm x 20mm Heavy-duty griddle plate – ribbed 300RH chromed	£2,775.00
PGH920R5*	900mm x 20mm Heavy-duty griddle plate – ribbed 450RH	£2,820.00
PGH920R9*	900mm x 20mm Heavy-duty griddle plate – ribbed full	£2,790.00
PGH920R5C*	900mm x 20mm Heavy-duty griddle plate – 450RH chromed	£2,855.00

Note: The standard plate is not included when ordering an optional griddle plate surface.
*Options must be specified at the placement of order.

1200mm GAS GRIDDLE | BENCH MODEL

GP518-B   31 £6,455.00

GP518-B

STANDARD PLATE SUPPLIED | Smooth machined finish mild steel plate PGH1220

1200mm GAS GRIDDLE | CABINET BASE (RACKING KIT NOT INCLUDED)

GP518-CB   31 £7,180.00

GP518-CB

OPTIONAL | **228791** Gastronorm racking kit 1/1 GN / 4 position / 1200mm Cabinet Base Accommodates 1 or 2 Racking Kits £235.00

STANDARD PLATE SUPPLIED | Smooth machined finish mild steel plate PGH1220

Choice of griddle surfaces: Simply order the optional griddle plate model number and unit is supplied with your nominated surface. View options page 31.
Note: The standard plate is not included when ordering an optional griddle plate surface.

GAS GRIDDLES

Model	Dimensions	Gas Power kW	Price (exc. VAT)
-------	------------	--------------	------------------



GP518-LS

1200mm GAS GRIDDLE | LEG STAND



GP518-LS

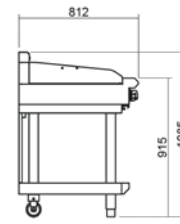
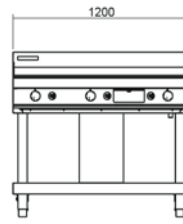

31

£6,660.00

STANDARD PLATE SUPPLIED

Smooth machined finish mild steel plate PGH1220

1200mm GAS GRIDDLE | REFRIGERATED BASE, 2 x 1/1 GN DRAWERS / 1 x 1/1 GN DOOR



GP518-RB

Electrical requirements:
220-240Vac,
50Hz, 1P+N+E, 1.8A,
3 pin 13A plug cordset fitted

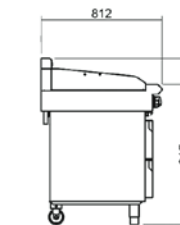
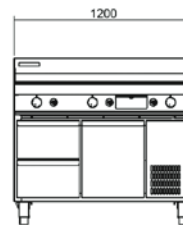

31

£10,775.00

STANDARD PLATE SUPPLIED







Smooth machined finish mild steel plate PGH1220

OPTIONAL EXTRAS | 1200mm GRIDDLE PLATE SURFACES – CHROMED/RIBBED

PGH1220C*	1200mm x 20mm Heavy-duty griddle plate – chromed	£3,500.00
PGH1220R4*	1200mm x 20mm Heavy-duty griddle plate – ribbed 400RH	£3,345.00
PGH1220R4C*	1200mm x 20mm Heavy-duty griddle plate – ribbed 400RH chromed	£3,345.00
PGH1220R6*	1200mm x 20mm Heavy-duty griddle plate – ribbed 600RH	£3,965.00
PGH1220R12*	1200mm x 20mm Heavy-duty griddle plate – ribbed full	£3,320.00

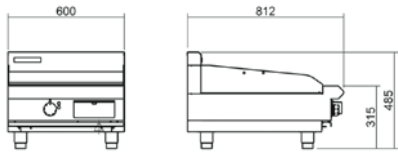
Note: The standard plate is not included when ordering an optional griddle plate surface.
*Options must be specified at the placement of order.

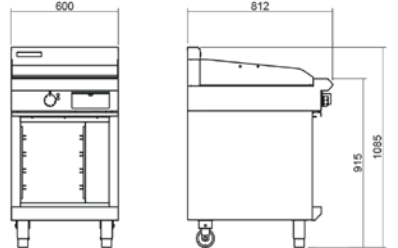
ELECTRIC GRIDDLES

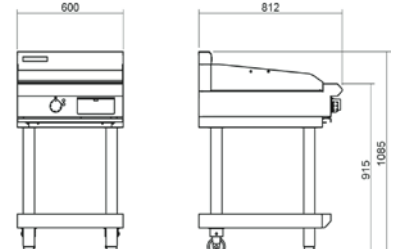
Model	Dimensions	Price (exc. VAT)
600mm ELECTRIC GRIDDLE BENCH MODEL 		
 <p>EP514-B</p> <p>Electrical requirements: 7.2kW, 230-240Vac, 50/60Hz, 1P+N+E, 30A</p>		<p>£4,305.00</p>
EP514-B	STANDARD PLATE SUPPLIED	Smooth machined finish mild steel plate PEH620
600mm ELECTRIC GRIDDLE CABINET BASE (RACKING KIT NOT INCLUDED) 		
 <p>EP514-CB</p> <p>Electrical requirements: 7.2kW, 230-240Vac, 50/60Hz, 1P+N+E, 30A</p>		<p>£4,670.00</p>
EP514-CB	OPTIONAL	228791 Gastronorm racking kit 1/1 GN / 4 position £235.00
	STANDARD PLATE SUPPLIED	Smooth machined finish mild steel plate PEH620
600mm ELECTRIC GRIDDLE LEG STAND 		
 <p>EP514-LS</p> <p>Electrical requirements: 7.2kW, 230-240Vac, 50/60Hz, 1P+N+E, 30A</p>		<p>£4,485.00</p>
EP514-LS	STANDARD PLATE SUPPLIED	Smooth machined finish mild steel plate PEH620







OPTIONAL | 600mm GRIDDLE PLATE SURFACES - CHROMED/RIBBED

PEH620C*	600mm x 20mm Heavy-duty griddle plate – chromed	£2,265.00
PEH620R3C*	600mm x 20mm Heavy-duty griddle plate – ribbed 300RH chromed	£2,315.00
PEH620R6*	600mm x 20mm Heavy-duty griddle plate – ribbed full	£1,935.00
PEH620R6C*	600mm x 20mm Heavy-duty griddle plate – ribbed full chromed	£2,070.00

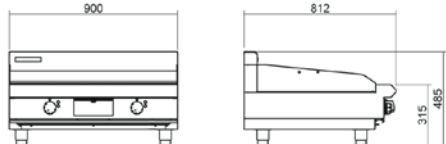
Note: The standard plate is not included when ordering an optional griddle plate surface.
*Options must be specified at the placement of order.

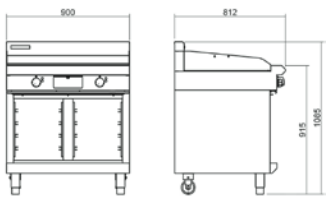
Choice of griddle surfaces: Simply order the optional griddle plate model number and unit is supplied with your nominated surface. View options above.

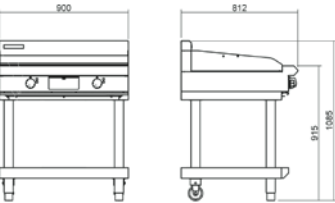
ELECTRIC GRIDDLES

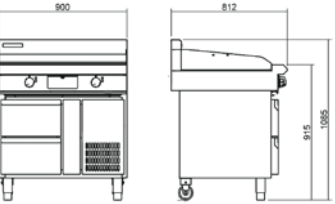
Model	Dimensions	Price (exc. VAT)
900mm ELECTRIC GRIDDLE BENCH MODEL		
 <p>EP516-B</p> <p>Electrical requirements: 12kW, 400-415Vac, 50/60Hz, 3P+N+E, 17A</p>		<p>£5,015.00</p>
<p>STANDARD PLATE SUPPLIED Smooth machined finish mild steel plate PEH920</p>		
900mm ELECTRIC GRIDDLE CABINET BASE (RACKING KIT NOT INCLUDED)		
 <p>EP516-CB</p> <p>Electrical requirements: 12kW, 400-415Vac, 50/60Hz, 3P+N+E, 17A</p>		<p>£5,550.00</p>
<p>OPTIONAL 228791 Gastronorm racking kit 1/1 GN / 4 position / 900mm Cabinet Base Accommodates 1 or 2 Racking Kits £235.00</p>		
<p>STANDARD PLATE SUPPLIED Smooth machined finish mild steel plate PEH1220</p>		
900mm ELECTRIC GRIDDLE LEG STAND		
 <p>EP516-LS</p> <p>Electrical requirements: 12kW, 400-415Vac, 50/60Hz, 3P+N+E, 25A</p>		<p>£5,410.00</p>
<p>STANDARD PLATE SUPPLIED Smooth machined finish mild steel plate PEH920</p>		
900mm ELECTRIC GRIDDLE REFRIGERATED BASE, 2 x 1/1 GN DRAWERS		
 <p>EP516-RB</p> <p>Electrical requirements: 12kW, 400-415Vac, 50/60Hz, 3P+N+E, 25A 3 pin 13A plug, cordset 1.8</p>		<p>£8,085.00</p>
<p>STANDARD PLATE SUPPLIED Smooth machined finish mild steel plate PEH920</p>		

Choice of griddle surfaces: Simply order the optional griddle plate model number and unit is supplied with your nominated surface. View options page 34.

ELECTRIC GRIDDLES

Model	Dimensions	Price (exc. VAT)
-------	------------	------------------

OPTIONAL | 900mm GRIDDLE PLATE SURFACES - CHROMED/RIBBED

PEH920C*	900mm x 20mm Heavy-duty griddle plate – chromed	£2,545.00
PEH920R3*	900mm x 20mm Heavy-duty griddle plate – ribbed 300RH	£2,600.00
PEH920R3C*	900mm x 20mm Heavy-duty griddle plate – ribbed 300RH chromed	£2,745.00
PEH920R5*	900mm x 20mm Heavy-duty griddle plate – ribbed 450RH	£2,650.00
PEH920R9*	900mm x 20mm Heavy-duty griddle plate – ribbed full	£2,685.00

Note: The standard plate is not included when ordering an optional griddle plate surface.
*Options must be specified at the placement of order.

1200mm ELECTRIC GRIDDLE | BENCH MODEL

EP518-B

Electrical requirements:
16.2kW, 400-415Vac, 50/60Hz,
3P+N+E, 25A



£6,110.00

STANDARD PLATE SUPPLIED | Smooth machined finish mild steel plate PEH1220

1200mm ELECTRIC GRIDDLE | CABINET BASE (RACKING KIT NOT INCLUDED)

EP518-CB

Electrical requirements:
16.2kW, 400-415Vac, 50/60Hz,
3P+N+E, 25A

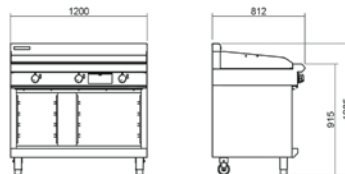

£6,825.00

OPTIONAL | 228791 Gastronorm racking kit 1/1 GN / 4 position / 1200mm Cabinet Base Accommodates 1 or 2 Racking Kits £235.00

STANDARD PLATE SUPPLIED | Smooth machined finish mild steel plate PEH1220



EP518-LS

1200mm ELECTRIC GRIDDLE | LEG STAND

EP518-LS

Electrical requirements:
16.2kW, 400-415Vac, 50/60Hz,
3P+N+E, 25A

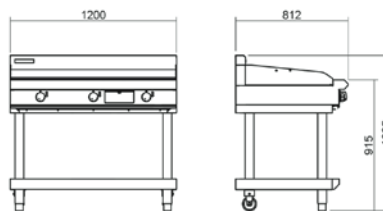

£6,455.00

STANDARD PLATE SUPPLIED | Smooth machined finish mild steel plate PEH1220

Choice of griddle surfaces: Simply order the optional griddle plate model number and unit is supplied with your nominated surface. View options page 35.

ELECTRIC GRIDDLES

Model	Dimensions	Price (exc. VAT)
1200mm ELECTRIC GRIDDLE REFRIGERATED BASE, 2 x 1/1 GN DRAWERS / 1 x 1/1 GN DOOR ⚡		

EP518-RB

Electrical requirements:
16.2kW, 400-415Vac, 50/60Hz,
3P+N+E

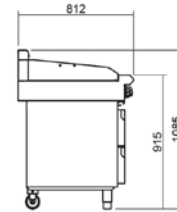
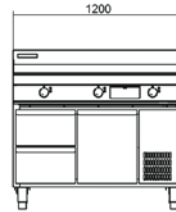

£9,710.00

STANDARD PLATE SUPPLIED | Smooth machined finish mild steel plate PEH1220

OPTIONAL | 1200mm GRIDDLE PLATE SURFACES - CHROMED/RIBBED

PEH1220C*	1200mm x 20mm Heavy-duty griddle plate – chromed	£3,140.00
PEH1220R4C*	1200mm x 20mm Heavy-duty griddle plate – ribbed 400RH chromed	£3,160.00
PEH1220R12*	1200mm x 20mm Heavy-duty griddle plate – ribbed full	£2,730.00

Note: The standard plate is not included when ordering an optional griddle plate surface.
*Options must be specified at the placement of order.

Choice of griddle surfaces: Simply order the optional griddle plate model number and unit is supplied with your nominated surface. View options above.

GAS GRIDDLE OVENS

Model	Dimensions	Gas Power kW	Price (exc. VAT)
-------	------------	--------------	------------------



GPE506

900mm GAS GRIDDLE | ELECTRIC STATIC OVEN RANGE - 2/1 GN



GPE506 23 £7,165.00

Electrical requirements:
6.5kW, 230-240Vac, 50/60Hz,
1P+N+E, 27A standard or 6.5kW,
400-415Vac, 50/60Hz,
3P+N+E, 10A

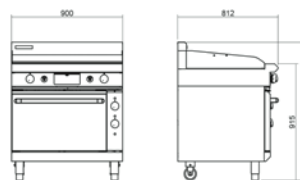

STANDARD PLATE SUPPLIED | Smooth machined finish mild steel plate PGH920



GPE56

900mm GAS GRIDDLE | ELECTRIC CONVECTION OVEN RANGE - 2/1 GN



GPE56 23 £7,855.00

Electrical requirements:
6.5kW, 230-240Vac, 50/60Hz,
1P+N+E, 27.7A standard or 6.6kW,
400-415Vac, 50/60Hz,
3P+N+E, 10A

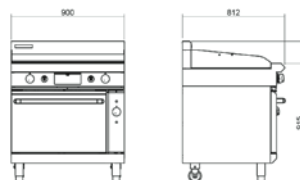

STANDARD PLATE SUPPLIED | Smooth machined finish mild steel plate PGH920

OPTIONAL | 900mm GRIDDLE PLATE SURFACES - CHROMED/RIBBED

PGH920C*	900mm x 20mm Heavy-duty griddle plate – chromed	£2,710.00
PGH920R3*	900mm x 20mm Heavy-duty griddle plate – ribbed 300RH	£2,675.00
PGH920R3C*	900mm x 20mm Heavy-duty griddle plate – ribbed 300RH chromed	£2,775.00
PGH920R5*	900mm x 20mm Heavy-duty griddle plate – ribbed 450RH	£2,820.00
PGH920R9*	900mm x 20mm Heavy-duty griddle plate – ribbed full	£2,790.00
PGH920R5C*	900mm x 20mm Heavy-duty griddle plate – 450RH chromed	£2,855.00

Note: The standard plate is not included when ordering an optional griddle plate surface.
*Options must be specified at the placement of order.

Choice of griddle surfaces: Simply order the optional griddle plate model number and unit is supplied with your nominated surface. View options above.

GAS GRIDDLE OVENS

Model	Dimensions	Gas Power kW	Price (exc. VAT)
-------	------------	--------------	------------------



GPE508

1200mm GAS GRIDDLE | ELECTRIC STATIC OVEN RANGE – 2/1 GN



GPE508

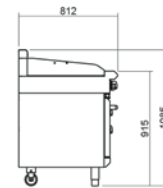
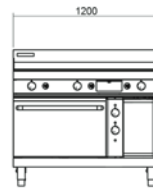

31

£8,615.00

Electrical requirements:
6.5kW, 230-240Vac, 50/60Hz,
1P+N+E, 27A standard or
6.5kW, 400-415Vac, 50/60Hz,
3P+N+E, 10A

STANDARD PLATE SUPPLIED | Smooth machined finish mild steel plate PGH1220



GPE58

1200mm GAS GRIDDLE | ELECTRIC CONVECTION OVEN RANGE – 2/1 GN



GPE58

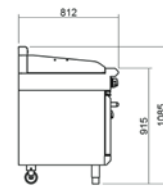
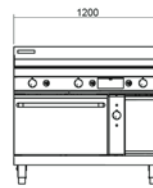

31

£9,340.00

Electrical requirements:
6.6kW, 230-240Vac, 50/60Hz,
1P+N+E, 27.7A standard or
6.6kW, 400-415Vac, 50/60Hz,
3P+N+E, 10A

STANDARD PLATE SUPPLIED | Smooth machined finish mild steel plate PGH1220

OPTIONAL | 1200mm GRIDDLE PLATE SURFACES - CHROMED/RIBBED

PGH1220C*	1200mm x 20mm Heavy-duty griddle plate – chromed	£3,500.00
PGH1220R4*	1200mm x 20mm Heavy-duty griddle plate – ribbed 400RH	£3,345.00
PGH1220R4C*	1200mm x 20mm Heavy-duty griddle plate – ribbed 400RH chromed	£3,345.00
PGH1220R6*	1200mm x 20mm Heavy-duty griddle plate – ribbed 600RH	£3,965.00
PGH1220R12*	1200mm x 20mm Heavy-duty griddle plate – ribbed full	£3,320.00

OPTIONAL EXTRAS | GAS GRIDDLE / GRIDDLE OVENS

228566	Griddle scraper tool C/W blades	£60.00
228567	Smooth plate scraper blades (pack of 10 blades)	£65.00
228568	Ribbed plate scraper blade (individual blade)	£30.00
Flex3/4/51	Flexihose 3/4 (flexible quick coupling hose & tether chain)	£225.00

Note: The standard plate is not included when ordering an optional griddle plate surface.
*Options must be specified at the placement of order.

Choice of griddle surfaces: Simply order the optional griddle plate model number and unit is supplied with your nominated surface. View options above.

GAS GRIDDLE TOASTER

Model	Dimensions	Gas Power kW	Price (exc. VAT)
-------	------------	--------------	------------------



G55T

600mm | GRIDDLE TOASTER



G55T

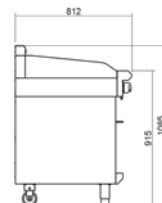

12

£3,770.00

ELECTRIC GRIDDLE OVENS

Model	Dimensions	Price (exc. VAT)
-------	------------	------------------



EP506

900mm ELECTRIC GRIDDLE | ELECTRIC STATIC OVEN RANGE – 2/1 GN

EP506
Electrical requirements:
 18.5kW, 400-415Vac, 50/60Hz,
 3P+N+E, 26A

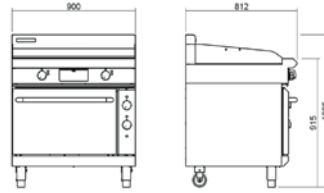

£7,165.00

STANDARD PLATE SUPPLIED | Smooth machined finish mild steel plate PEH920



EP56

900mm ELECTRIC GRIDDLE | ELECTRIC CONVECTION OVEN RANGE – 2/1 GN

EP56
Electrical requirements:
 18.6kW, 400-415Vac, 50/60Hz,
 3P+N+E, 27A

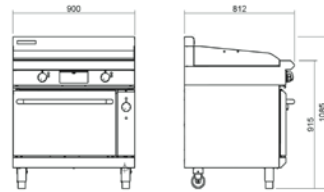

£7,855.00

STANDARD PLATE SUPPLIED | Smooth machined finish mild steel plate PEH920

OPTIONAL | 900mm GRIDDLE PLATE SURFACES - CHROMED/RIBBED

PEH920C*	900mm x 20mm Heavy-duty griddle plate – chromed	£2,545.00
PEH920R3*	900mm x 20mm Heavy-duty griddle plate – ribbed 300RH	£2,600.00
PEH920R3C*	900mm x 20mm Heavy-duty griddle plate – ribbed 300RH chromed	£2,745.00
PEH920R5*	900mm x 20mm Heavy-duty griddle plate – ribbed 450RH	£2,650.00
PEH920R9*	900mm x 20mm Heavy-duty griddle plate – ribbed full	£2,685.00









OPTIONAL EXTRAS | ELECTRIC GRIDDLE / GRIDDLE OVENS

228566	Griddle scraper tool C/W blades	£60.00
228567	Smooth plate scraper blades (pack of 5 blades)	£65.00
228807	Mobile castor kit (set of 2 lockable)	£120.00

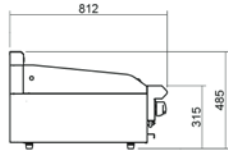
Note: The standard plate is not included when ordering an optional griddle plate surface.
 *Options must be specified at the placement of order.

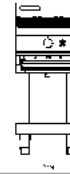
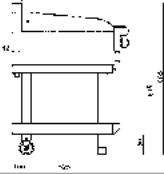
Choice of griddle surfaces: Simply order the optional griddle plate model number and unit is supplied with your nominated surface. View options above.

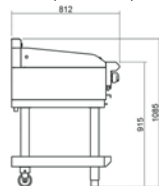
GAS CHARRILLS

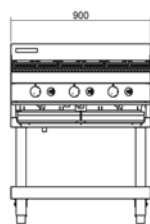
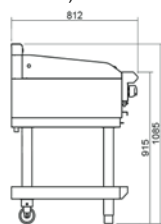
Model	Chargrill	Dimensions	Gas Power kW	Price (exc. VAT)
300mm GAS CHARRILL BENCH MODEL				
G592-B		 	9.8	£2,115.00
G593 LS GAS CHARRILL				
Dimensions: mm (w x d x h)				
G593-LS		 	14.2	£3,835.00
G593-B		450 x 812 x 585	14.2	£3,495.00
600mm GAS CHARRILL LEG STAND				
Dimensions: mm (w x d x h)				
G594-LS		 	18.6	£4,200.00
G594-B		600 x 812 x 585	18.6	£3,835.00
900mm GAS CHARRILL LEG STAND				
Dimensions: mm (w x d x h)				
G596-LS		 	29.3	£4,505.00
G596-B		900 x 812 x 585	29.3	£4,150.00

G592-B



G593-LS



G594-LS



G596-LS



GAS CHARGRILLS

Model	Chargrill	Dimensions	Gas Power kW	Price (exc. VAT)
-------	-----------	------------	--------------	------------------



G598-LS

1200mm GAS CHARGRILL | LEG STAND

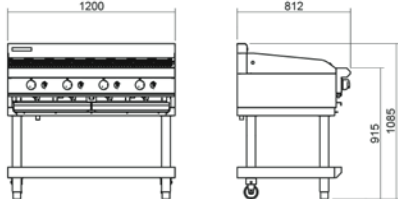

Model	Chargrill	Dimensions: mm (w x d x h)	Gas Power kW	Price (exc. VAT)
G598-LS			39.1	£5,240.00
G598-B		1200 x 812 x 585	39.1	£4,890.00



Example with drop on plate fitted.

Model	Description	Price (exc. VAT)
-------	-------------	------------------

OPTIONAL EXTRAS GAS CHARGRILLS

228787	Grate Scraper Tool	£200.00
227002	Drop on griddle plate 300mm	£135.00
227003	Drop on griddle plate 450mm	£225.00
228807	Mobile castor kit (set of 4 castors, 2 lockable)	£120.00
Flex3/4/51	Flexi hose 3/4 (flexible quick coupling hose & tether chain)	£225.00
230707	Heavy duty 12mm thick steel griddle plate 300mm	£410.00
230710	Heavy duty 12mm thick steel griddle plate 450mm	£510.00

FRYERS, PASTA COOKERS, SALAMANDERS

BLUE SEAL EVOLUTION SERIES®

Blue Seal has long been recognised for the quality and performance of its Fryers. The Evolution Series takes this a stage further with a sleeker, more streamlined Fryer range - available in 450 or 600mm single or twin pan versions. Gas units feature Blue Seal's unique Vee Ray technology, incorporating patented infrared burners for industry leading frying output and recovery.

All Fryers are available with either mechanical or digital controls. Digital control models offer precise temperature control, three product timers, as well as time and temperature digital display. Twin pan models have independent digital controls for each pan and six product timers.

Blue Seal Evolution Series Gas and Electric Salamanders are versatile, easy to use and well equipped with performance features. They can be used for melting, grilling, gratinating and toasting.

Gas models feature energy efficient high-speed infrared burners for fast results. Electric models feature powerful 3kW twin coil elements for optimum cooking performance.

Both gas and electric options will accept a Gastronorm GN 1/1 tray. An optional branding plate is ideal for cooking fish or steak.

The Blue Seal Evolution Series Pasta Cooker is built for speed. Fully modular, and featuring a unique single pan design, it comes well equipped for the continuous production of perfect pasta.

From variable high boil to standby simmer, our patented infrared burner system maintains constant water temperature and enables faster turnaround of product through outstanding recovery times from Low heat settings.

The standard provision of four baskets allows four different pastas to be cooked at the same time.

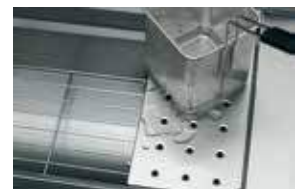

GAS AND ELECTRIC SALAMANDERS

Model	Dimensions	Gas Power kW	Price (exc. VAT)
900mm GAS SALAMANDER			



G91B

G91B
Four position racking
(flat or inclined)
includes wall mounting
bracket and branding plate

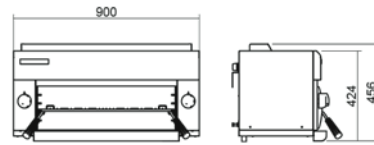

8.8 £2,340.00

OPTIONAL EXTRAS GAS SALAMANDER

013048	100mm high feet for bench mounting (set of 4)	£95.00
013418B	Branding plate – 620 x 320mm	£225.00
BS91	Floor stand	£855.00
B90S-L	Bench stand	£1,790.00

900mm | ELECTRIC SALAMANDER



E91B

E91B
Four position racking
(flat or inclined)
Includes wall mounting
bracket and branding plate

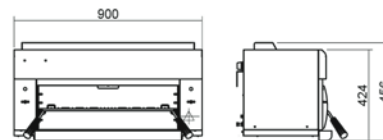

£2,340.00

Electrical requirements:
6kW, 230-240Vac, 50/60Hz,
1P+N+E, 25A

OPTIONAL EXTRAS ELECTRIC SALAMANDER

013048	100mm high feet for bench mounting (set of 4)	£95.00
013418B	Branding plate – 620 x 320mm	£225.00
BS91	Floor stand	£855.00
B90S-L	Bench stand	£1,790.00

QSET60 | RAPID HEAT RISE & FALL GRILL

QSE60



QSET60/QSE60

QSET60	600mm wide x 450mm deep x 500mm high	4	£3,485.00
QSET60 Plate detector as standard.			
QSE60	600mm wide x 450mm deep x 500mm high	4	£3,235.00
9003	Wall brackets		£175.00

600mm | SALAMANDER BENCH

To suit QSET60/QSE60 rise and fall salamanders.



B60S-L	Leg stand	£1,790.00
B60S-CB	Cabinet base	£1,900.00

GAS FRYERS

Model	Dimensions	Gas Power kW	Price (exc. VAT)
400mm	SINGLE PAN GAS FRYER 400mm	NEW PRODUCT	



GT18

GT18
 400mm wide single pan fryer
 Stainless steel exterior
 18 litre oil capacity
 V- tank with cool zone
 Manual pilot ignition
 30mm drain valve
 90MJ multi- jet target burner
 Fully modular

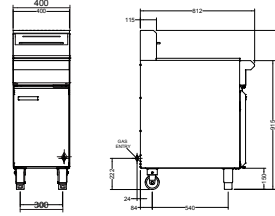

25 £2,590.00



450mm	VEE RAY SINGLE PAN GAS FRYERS		
--------------	--------------------------------------	--	--



GT45

GT45
 Single pan
 20 Litre capacity
 Mechanical controls
 Supplied with two standard baskets

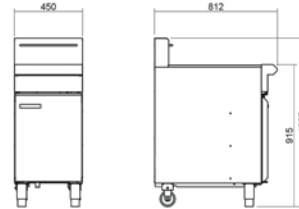

25 £3,945.00



GT45E	Single pan 20 Litre capacity Digital display electronic controls Supplied with two standard baskets	25	£4,485.00
--------------	--	----	-----------

Electrical requirements:
 230-240Vac, 50/60Hz, 1P+N+E, 0.5A
 3 Pin 13A cordset fitted

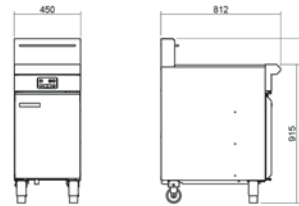

450mm	VEE RAY TWIN PAN GAS FRYERS		
--------------	------------------------------------	--	--



GT46E

GT46
 Twin pan
 13 Litre capacity each pan
 Mechanical controls
 Supplied with two standard baskets

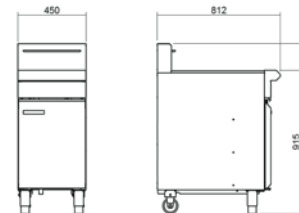

25 £4,060.00



GT46E	Twin pan 13 Litre capacity each pan Digital display electronic controls Supplied with two standard baskets	25	£5,350.00
--------------	---	----	-----------

Electrical requirements:
 230-240Vac, 50/60Hz, 1P+N+E, 0.5A
 3 Pin 13A cordset fitted

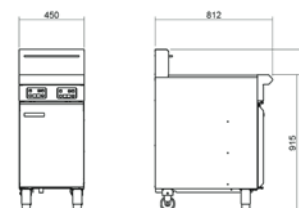

GAS FRYERS

Model	Dimensions	Gas Power kW	Price (exc. VAT)
-------	------------	--------------	------------------



GT60E

600mm | VEE RAY SINGLE PAN GAS FRYERS



GT60

Single pan
31 Litre capacity
Mechanical controls
Supplied with two large baskets

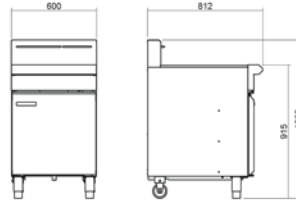

25

£5,450.00

GT60E

Single pan
31 Litre capacity
Digital display electronic controls
Supplied with two large baskets

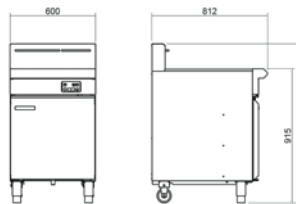

25

£6,170.00

Electrical requirements:

230-240Vac, 50/60Hz, 1P+N+E, 0.5A
3 Pin 13A cordset fitted



CS45E

CS45E | EVOLUTION CS45 CHIP SKUTTLE WITH ELECTRIC CERAMIC HEATER



CS45E

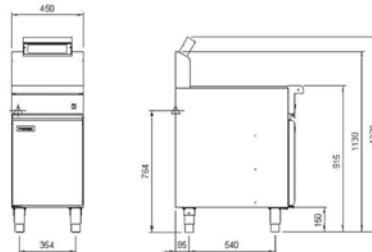

3kW
13amp

£2,000.00



18019

23220

OPTIONAL EXTRAS | GAS FRYERS

018019	· Fryer baskets standard to suit GT45, GT46	£125.00
023220	· Fryer baskets large to suit GT60	£155.00
228898	· Fryer splashguards LH (all gas fryers)	£95.00
228899	· Fryer splashguards RH (all gas fryers)	£95.00
228127	· Fish plate GT45	£70.00
228565	· Fish plate GT46	£70.00
228128	· Fish plate GT60	£75.00
228761	· Fryer lift off lid GT45	£70.00
228762	· Fryer lift off lid GT60	£70.00
018176	· Fryer drain stick (all fryers)	£50.00
024705	· Fryer drain adaptor kit (allows use of 24710 drain extension) (all fryers)	£135.00
024710	· Fryer drain extension kit (to use GT45, GT46)	£190.00
228807	· Mobile castor kit (set of 2 lockable)	£120.00
Flex3/4/51	Flexihose 3/4 (flexible quick coupling hose & tether chain)	£225.00

Note: Options must be specified at the placement of order.

ELECTRIC FRYERS

Model	Dimensions	Price (exc. VAT)
-------	------------	------------------

450mm SINGLE PAN ELECTRIC FRYERS



E43

E43
Single pan
27 Litre capacity
Mechanical controls
Supplied with two baskets

Electrical requirements:
17kW, 400-415Vac, 50/60Hz,
3P+N+E, 24A

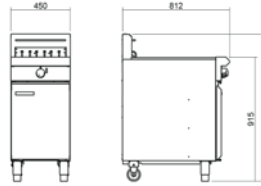

£3,945.00

E43E
Single pan
27 Litre capacity
Digital display electronic controls
Supplied with two baskets

Electrical requirements:
17kW, 400-415Vac, 50/60Hz,
3P+N+E, 24A

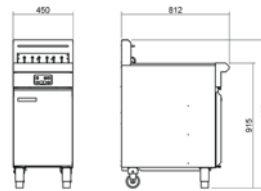

£4,880.00

450mm TWIN PAN ELECTRIC FRYERS



E44E

E44
Twin pan
12 Litre capacity each pan
Mechanical controls
Supplied with two baskets

Electrical requirements:
17kW, 400-415Vac, 50/60Hz,
3P+N+E, 24A

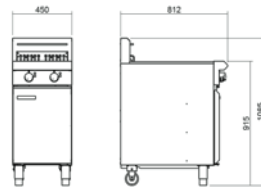

£4,060.00

E44E
Twin pan
12 Litre capacity each pan
Digital display electronic controls
Supplied with two baskets

Electrical requirements:
17kW, 400-415Vac, 50/60Hz,
3P+N+E, 24A

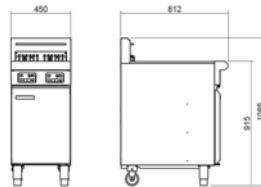

£4,980.00

OPTIONAL EXTRAS | ELECTRIC FRYERS



018019

018019	· Fryer baskets standard to suit E43, E44	£125.00
228898	· Fryer splashguards LH (all electric fryers)	£95.00
228899	· Fryer splashguards RH (all electric fryers)	£95.00
228761	· Fryer lift off lid E43, E44 series	£70.00
018176	· Fryer drain stick (all fryers)	£50.00
228807	· Mobile castor kit (set of 2 lockable)	£120.00

Note: Options must be specified at the placement of order.

FRYER FILTERS



Model	Dimensions	Price (exc. VAT)
-------	------------	------------------

FILTAMAX | FRYER FILTERS



EF30 20 Litre

Reusable Filter Bag.
Filtamax Filter fits under the following: GT45, GT45E, GT46, GT46E

Electrical requirements:
0.77kW, 220-240Vac, 50Hz, 1P+N+E, 6.4A, 3 PIN, 10A Cordset fitted

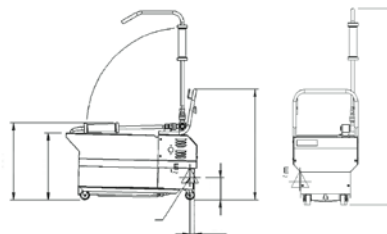

£2,995.00

EF35 30 Litre

Reusable Filter Bag.
Filtamax Filter cannot be stored under fryers.
E35 for use with E43, E43E, E44, E44E

Electrical requirements:
0.77kW, 220-240Vac, 50Hz, 1P+N+E, 6.4A, 3 PIN, Cordset fitted

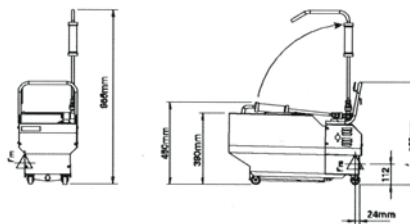

£3,160.00

EF40 32 Litre

Reusable Filter Bag.
Filtamax Filter fits under fryer model, GT60, GT60E

Electrical requirements:
0.77kW, 220-240Vac, 50Hz, 1P+N+E, 6.4A, 3 PIN, Cordset fitted

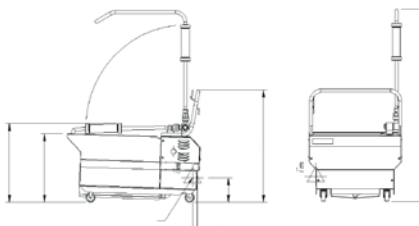

£3,730.00

OPTIONAL EXTRAS | FILTAMAX FRYER FILTERS

022815	Filter Pad Kit for Filtamax Pad Consumables Pack of 30	£210.00
020417	Flexible Filter Return Hose Arm	£825.00
SA1159	Filter extension arm fixed EF30, EF35 (for electric fryers)	£525.00

SINGLE PAN PASTA COOKERS



- High performance single pan pasta cooker
- Patented infra-red burner system
- Easy clean 316 grade stainless steel open pan
- 40 Litre water capacity
- Integrated water fill and starch skimming water faucet
- Six stainless steel pasta baskets supplied standard
- Incorporated basket drain stand
- Safety cut out thermostat for empty pan/water boil out
- Stainless steel exterior
- Easy service
- Fully modular

Model	Dimensions	Gas Power kW	Price (exc. VAT)
-------	------------	--------------	------------------

450mm | GAS PASTA COOKER



G47



G47
Single Tank
Pasta Cooker

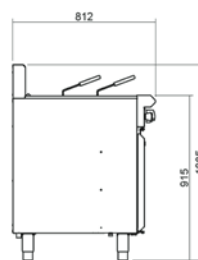
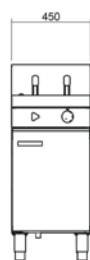

13.5

£4,465.00

Unit comes with six portion baskets as standard.

450mm | ELECTRIC PASTA COOKERS



E47



E47-7
Single phase

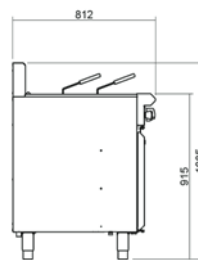
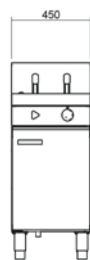

7.0

£4,465.00

E47
3 phase

10.5

£4,465.00

Unit comes with six portion baskets as standard.

OPTIONAL EXTRAS | PASTA COOKER BASKETS



229836

229837

229836
229837

Pasta Basket W 165mm x D 165mm x H 180mm
Pasta Basket W 320mm x D 165mm x H 180mm

£160.00
£205.00

Note: Pasta Cooker Basket Combinations:







- Six Square (standard supply) • Two square / one rectangular • Two large rectangular

238674
238819

L Hand W 165mm x 125mm
R Hand W 165mm x 125mm

£135.00
£135.00

IN-FILL TABLES

Model	Dimensions	Price (exc. VAT)
 <p>BS TABLE B30-C</p>	<p>300mm PROFILED IN-FILL TABLE</p> <p>Stainless steel Profiled In - Fill Table complete with stub back suitable for all Blue Seal Evolution Series products.</p>	<p>915mm h x 812mm d x 300mm w</p> <p>£1,005.00</p>
 <p>BS TABLE B30-L</p>	<p>300mm PROFILED IN-FILL TABLE</p> <p>Stainless steel Profiled In - Fill Table complete with stub back suitable for all Blue Seal Evolution Series products.</p>	<p>915mm h x 812mm d x 300mm w</p> <p>£915.00</p>
 <p>BS TABLE B45-L</p>	<p>450mm PROFILED IN-FILL TABLE</p> <p>Stainless steel Profiled In - Fill Table complete with stub back suitable for all Blue Seal Evolution Series products.</p>	<p>915mm h x 812mm d x 450mm w</p> <p>£1,140.00</p>
 <p>BS TABLE B60-L</p>	<p>600mm PROFILED IN-FILL TABLE</p> <p>Stainless steel Profiled In - Fill Table complete with stub back suitable for all Blue Seal Evolution Series products.</p>	<p>915mm h x 812mm d x 600mm w</p> <p>£1,255.00</p>
 <p>BS TABLE B90-L</p>	<p>900mm PROFILED IN-FILL TABLE</p> <p>Stainless steel Profiled In - Fill Table complete with stub back suitable for all Blue Seal Evolution Series products.</p>	<p>915mm h x 812mm d x 900mm w</p> <p>£1,455.00</p>
 <p>BS TABLE B90-RB</p>	<p>900mm PROFILED IN-FILL TABLE/REFRIGERATED BASE</p> <p>Stainless steel Profiled In - Fill Table complete with stub back suitable for all Blue Seal Evolution Series products.</p>	<p>915mm h x 812mm d x 900mm w</p> <p>£3,410.00</p> <p>Refrigerated base. 2 draw GN-sized.</p>
 <p>BS TABLE B90S-L</p>	<p>900mm PROFILED IN-FILL TABLE/SALAMANDER GRILL BRACKET</p> <p>Stainless steel Profiled In - Fill Table complete with stub back suitable for all Blue Seal Evolution Series products.</p>	<p>915mm h x 812mm d x 900mm w</p> <p>£1,790.00</p> <p>Fitted with Salamander grill bracket.</p>



Model	Dimensions	Price (exc. VAT)
600mm	SALAMANDER BENCH	
To suit QSET60/QSE60 rise and fall salamanders.		
B60S-L Leg stand		£1,790.00
B60S-CB Cabinet base		£1,900.00

OPTIONAL EXTRAS FOR BLUE SEAL GAS AND ELECTRIC EQUIPMENT

Product	Model	Description	Price (exc. VAT)
OPTIONAL EXTRAS	BLUE SEAL GAS AND ELECTRIC EQUIPMENT		
COOKTOP / RANGES	230013	Bench shield, fits LH or RH of open burners	£110.00
CABINET BASES	228791	Gastronorm racking kit / cabinets standard w/o racking / 900mm / 1200mm cabinet bases £240 accommodates 1 or 2 racking kits fits 1/1 GN or 2/1 GN6	£235.00
RANGE OVENS	228106	Oven rack to suit G504, G505, G524	£75.00
	227896	Oven rack to suit G506, G508	£80.00
TARGET TOPS	014997	Casting hook	£65.00
GRIDDLES / GRIDDLE OVENS	228566	Griddle scraper tool c/w blades	£60.00
	228567	Smooth plate scraper blades (Pack of 10)	£65.00
	228568	Ribbed plate scraper blade (individual blade)	£30.00
CHARGRILLS	228787	Grate scraper tool	£200.00
	227002	Chargrill griddle plate 300mm	£135.00
	227003	Chargrill griddle plate 450mm	£225.00
SALAMANDERS	013418	Salamander branding kit / one double-sided ribbed aluminium branding plate / fits both rack system models	£225.00
	013048	100mm high feet for bench mounting (4 per salamander)	£95.00
FRYERS	018019	Fryer baskets standard to suit GT45, GT46 gas series, E43, E44	£125.00
	023220	Fryer baskets large to suit GT60, GT60-HPO	£155.00
	228898	Fryer splashguards LH (all fryers)	£95.00
	228899	Fryer splashguards RH (all fryers)	£95.00
	228127	Fish plate GT45	£70.00
	228565	Fish plate GT46	£70.00
	228128	Fish plate GT60, GT60-HPO--	£75.00
	228761	Fryer lift off lid GT45, E43, E44	£70.00
	228762	Fryer lift off lid GT60, GT60-HPO	£70.00
	018176	Fryer drain stick (all fryers)	£50.00
	024705	Fryer drain adaptor kit (allows use of 24710 drain extension) (all fryers)	£135.00
	024710	Fryer drain extension kit to use GT45, GT46, E43, E44 series with 40 litre filtamax machine	£190.00
FRYER FILTER	022815	Filter pad kit for Filtamax (upgrades Filtamax to carbon pad system)	£210.00
	020417	Filter flexible hose return arm	£825.00
	SA1559	Filter extension arm fixed EF30, EF35	£525.00
	SA1556	Filter extension arm fixed EF40	£525.00

JOINING CAPS | NOT AVAILABLE

- Cooktops Open – Griddle Toaster
- Cooktops Open – Cooktop Electric
- Cooktops Open – Cooktop Electric Griddle
- Cooktop Griddle – Cooktop Electric
- Target Top – Griddle Toaster
- Fryer Gas – Fryer Electric
- Fryer Gas – Bratt Pan
- Fryer Electric – Fryer Gas
- Fryer Electric – Bratt Pan
- Bratt Pan – Fryer Gas
- Bratt Pan – Fryer Electric
- Bratt Pan – Griddle Toaster
- Griddle Toaster – Cooktop Open
- Griddle Toaster – Target Top
- Griddle Toaster – Bratt Pan
- Griddle Toaster – Cooktop Electric
- Cooktop Electric – Cooktop Open
- Cooktop Electric – Cooktop Griddle
- Cooktop Electric – Griddle Toaster
- Cooktop Electric – Cooktop Open

Note: Options must be specified at the placement of order.

JOINING CAPS FOR BLUE SEAL GAS AND ELECTRIC EQUIPMENT

Part No.	Type	Application / By Products	Notes	Price (exc. VAT)
JOINING CAPS FOR BLUE SEAL GAS AND ELECTRIC EQUIPMENT				
228579	C-C	Cooktops Open – Cooktops Open Cooktops Open – Chargrill Cooktops Open – Cooktop Griddle	Kit – Capping piece + 2 x levelling tabs Required if joined with griddle section	£50.00
228587	GP-CO	Griddles – Cooktops Open		£50.00
228595	TT-C	Target Top – Cooktops Open Target Tops - Chargrill Target Tops - Cooktop Griddles		£50.00
228889	TT-TT	Target Tops - Target Tops		£95.00
228890	TT-GP	Target Tops - Griddle		£95.00
228589	BP-BP	Bratt Pan – Bratt Pan		£50.00
228604	BP-C	Bratt Pan – Cooktop Open Bratt Pan - Chargrill Bratt Pan – Cooktops Electric Bratt Pan – Cooktop Griddle		£55.00
228891	BP-TT	Bratt Pan – Target Top		£95.00
228892	BP-GP	Bratt Pan – Griddle		£95.00
228893	G-G	Chargrill – Chargrill Chargrill – Cooktop Griddle Chargrill – Griddle Chargrill – Griddle Toaster Griddle Toaster – Griddle Toaster Griddle – Griddle Cooktop Griddle – Cooktop Griddle Electric Cooktop Griddle - Electric Cooktop Griddle	Type G-G Caps griddle raised sides of grills	£50.00
228894*	FG-GL	Fryer Gas – Cooktop Griddle Fryer Gas – Chargrill Caps over grill sides Fryer Gas – Griddle Fryer Gas – Griddle Toaster	FITS LH SIDE OF FRYER	£70.00
228895*	FG-GR	Fryer Gas – Cooktop Griddle Fryer Gas – Chargrill Caps over grill sides Fryer Gas – Griddle Fryer Gas – Griddle Toaster	FITS RH SIDE OF FRYER	£70.00
228896*	FE-GL	Fryer Electric – Cooktop Griddle Fryer Electric – Chargrill Fryer Electric – Griddle Fryer Electric – Griddle Toaster	FITS LH SIDE OF FRYER Caps over grill sides	£110.00
228897*	FE-GR	Fryer Electric – Cooktop Griddle Fryer Electric – Chargrill Fryer Electric – Griddle Fryer Electric – Griddle Toaster	FITS RH SIDE OF FRYER Caps over grill sides	£80.00
228600	FG-FG	Fryer Gas – Fryer Gas	Caps across 2 Tanks	£50.00
228601	FE-FE	Fryer Electric – Fryer Electric	Caps across 2 Tanks	£95.00
247924	FE-FE	E44-E44 only	Caps across 2 Tanks	£125.00

NOTE: PRODUCT GROUPS NOTED IN APPLICATION BY PRODUCT (PAIRS) CAN BE LOCATED WITH THE EXCEPTION OF JOINING CAPS MARKED * ARE DEDICATED LEFT OR RIGHT HAND SIDE FIT.

COBRA®

YOUR STYLE, YOUR WAY



Powerful, the Cobra Series is the solution for those who demand reliability and capability. Cobra is suited to a large range of eateries – anywhere that needs solid raw power, specific cooking equipment that offers cuisine flexibility when cooking a diverse menu.

COBRA® - MEDIUM DUTY MODULAR COOKING EQUIPMENT

Model	Hob Options	Dimensions	Gas kW / BTU	Price (exc. VAT)
-------	-------------	------------	--------------	------------------

GAS COOKTOPS

600mm GAS COOKTOPS 4 BURNER BENCH MODEL



C6D-B

C6D-B 4 Open burners, bench model			20	£1,835.00
C6C-B 2 Open burners, LH side, 300mm Griddle plate, RH side, bench model			75,790	
C6B-B 600mm Griddle plate, bench model			15	£2,105.00
			56,840	
			10	£2,380.00
			37,890	

Note: Flame failure standard on open burners.

600mm GAS COOKTOPS 4 BURNER OPEN CABINET BASE



C6D

C6D 4 Open burners, open cabinet base under			20	£1,855.00
C6C 2 Open burners, LH side, 300mm Griddle plate, RH side, open cabinet base under			75,790	
C6B 600mm Griddle plate, open cabinet base under			15	£2,405.00
			56,840	
			10	£2,675.00
			37,890	

Note: Flame failure standard on open burners.

900mm GAS COOKTOPS 6 BURNER BENCH MODEL



C9D-B

C9D-B 6 Open burners, bench model			30	£2,130.00
C9C-B 4 Open burners, LH side, 300mm Griddle plate, RH side, bench model			113,680	
C9B-B 2 Open burners, LH side, 600mm Griddle plate, bench model			25	£2,405.00
C9A-B 900mm Griddle plate, bench model			94,730	
			20	£2,675.00
			75,790	
			15	£2,945.00
			56,840	

Note: Flame failure standard on open burners.

Model	Hob Options	Dimensions	Gas kW / BTU	Price (exc. VAT)
-------	-------------	------------	--------------	------------------

GAS COOKTOPS

900mm GAS COOKTOPS | 6 BURNER OPEN CABINET BASE



C9B

C9D
6 Open burners,
open cabinet base under



30 £2,325.00

C9C
4 Open burners, LH side,
300mm griddle plate,
RH side, open cabinet
base under



25 £2,615.00

C9B
2 Open burners, LH side,
600mm griddle plate,
RH side, open cabinet
base under



20 £2,900.00

C9A
900mm Griddle plate,
open cabinet base under



15 £3,195.00

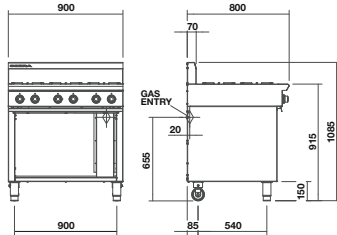

56,840

Note: Flame failure standard on open burners.

GAS RANGES

600mm GAS RANGES | GAS STATIC OVEN RANGE



CR6D

CR6D
4 Open burners,
static oven under



26.5 £2,420.00

CR6C
2 Open burners,
300mm griddle plate,
static oven under



88 £2,695.00

CR6B
600mm Griddle plate,
static oven under



64 £2,975.00

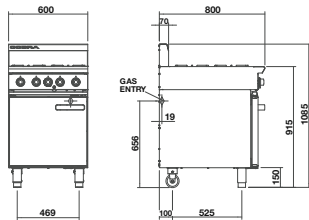

65,525

Note: Flame failure standard on open burners.

COBRA® - MEDIUM DUTY MODULAR COOKING EQUIPMENT

Model	Hob Options	Dimensions	Gas kW / BTU	Price (exc. VAT)
-------	-------------	------------	--------------	------------------

GAS RANGES

900mm GAS RANGES

GAS STATIC OVEN RANGE - 2/1 GN



CR9D
6 Open burners, 2/1 GN,
static oven under



37.5 £2,660.00

142,100

CR9C
4 Open burners 300mm
griddle plate, 2/1 GN,
static oven under



32.5 £3,215.00

123,150

CR9B
2 Open burners 600mm
griddle plate, 2/1 GN,
static oven under



27.5 £3,490.00

104,200

CR9A
900mm Griddle plate,
2/1 GN, static oven under



22.5 £3,765.00

85,260

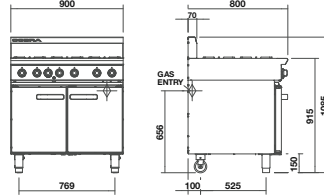

CR9C

Note: Flame failure standard on open burners.

OPTIONAL EXTRAS – GAS RANGES

233954	Oven rack to suit 600mm oven range	£50.00
230556	Oven rack to suit 900mm oven range	£60.00
UKCSP4	Plate shelf and splashback to suit 600mm oven range	£615.00
UKCSP6	Splashback, overshelf and grill shelf to suit 900mm oven range	£615.00

GAS BARBECUES



600mm GAS BARBECUE

BENCH MODEL



CB6-B
600mm BBQ, bench
model



18 £2,130.00

68,200

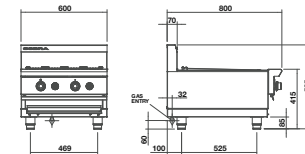

CB6-B

600mm GAS BARBECUE

OPEN CABINET BASE



CB6
600mm BBQ, mounted
on open cabinet base



18 £2,325.00

68,200

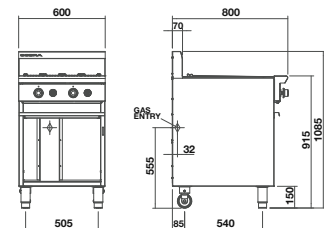

CB6

GAS RANGES, BARBECUES, SALAMANDER & GRIDDLE TOASTERS

Model	Hob Options	Dimensions	Gas kW / BTU	Price (exc. VAT)
-------	-------------	------------	--------------	------------------

GAS BARBECUES



900mm GAS BARBECUE | BENCH MODEL



CB9-B
900mm BBQ, bench model

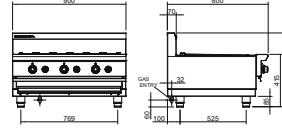

27
102,310
£2,600.00

CB9-B

900mm GAS BARBECUE | OPEN CABINET BASE



CB9
900mm BBQ, mounted on open cabinet base

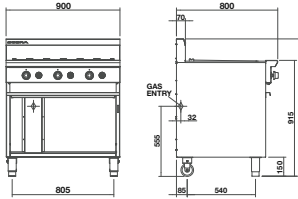

27
102,310
£2,840.00

CB9

GAS SALAMANDER

900mm GAS SALAMANDER



CS9
Four position racking (flat or inclined)

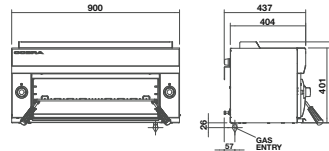

8.8
33,350
£1,870.00

CS9

OPTIONAL EXTRAS – SALAMANDER

013048	100mm high feet for bench mounting (set of 4)	£95.00
013418B	Branding plate - 620 x 320mm	£225.00

GAS GRIDDLE TOASTERS

600mm GAS GRIDDLE TOASTER



CT6
600mm Griddle, toaster compartment

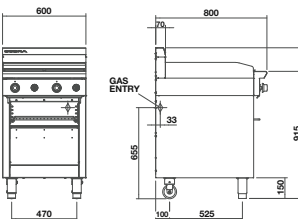

11
41,700
£2,515.00

CT6

COBRA® - MEDIUM DUTY MODULAR COOKING EQUIPMENT

Model	Hob Options	Dimensions	Gas kW / BTU	Price (exc. VAT)
-------	-------------	------------	--------------	------------------

GAS FRYER

400mm GAS FRYER

SINGLE PAN



CF2
18 Litre oil capacity,
mechanical thermostat
25kg / hr production rate
supplied with baskets & lid

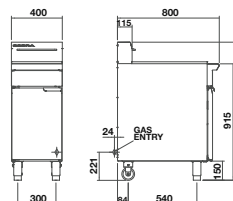

25 £1,950.00
85,250

CF2

OPTIONAL EXTRAS – GAS FRYER

237427	Fish plate	£50.00
237306	Joining cap	£50.00
237307	Splashguard LH 400FG-XL – general splashguard to fit side of fryer	£95.00
237308	Splashguard RH 400FG-XR – general splashguard to fit side of fryer	£95.00
237310	Splashguard LH 400FG-GL – splashguard to join fryer to cooktop griddles / barbecue / griddle toaster	£95.00
237311	Splashguard RH 400FG-GR – splashguard to join fryer to cooktop griddles / barbecue / griddle toaster	£95.00

GAS GRIDDLE TOASTERS, FRYER & COOKERS

Model	Hob Options	Dimensions	Gas kW / BTU	Price (exc. VAT)
-------	-------------	------------	--------------	------------------

GAS PASTA COOKER

450mm PASTA COOKER | SINGLE PAN



CP4
40 Litre water capacity, mechanical thermostat patented infra-red burner system, 6 stainless steel pasta baskets included

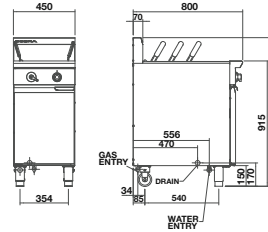

12
45,450
£4,415.00

CP4

OPTIONAL EXTRAS – GAS PASTA COOKER

238674	Pasta basket LH – 165mm x 165mm x 180mm	£135.00
238819	Pasta basket RH – 165mm x 165mm x 180mm	£135.00
240516	Conversion kit for gas noodle kit includes basket support tray and 5 noodle baskets	£320.00

GAS NOODLE COOKER

450mm NOODLE COOKER | SINGLE PAN



CN4
40 Litre water capacity, mechanical thermostat patented infra-red burner system, 5 stainless steel noodle baskets included

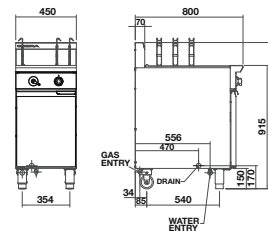

12
45,450
£4,415.00

CN4

OPTIONAL EXTRAS – GAS NOODLE COOKER

240507	Noodle basket	£55.00
--------	---------------	--------

COBRA® - MEDIUM DUTY MODULAR COOKING EQUIPMENT

Model	Dimensions	Price (exc. VAT)
-------	------------	------------------

INFILL BENCHES

300mm INFILL BENCH

LEG STAND



C300
300mm Infill bench
with leg stand

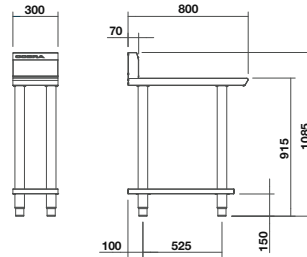

£715.00

C300

450mm INFILL BENCH

LEG STAND



C450
450mm Infill bench
with leg stand

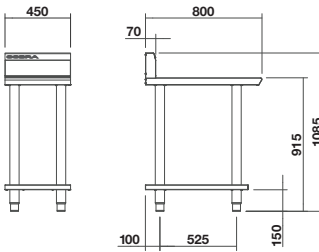

£830.00

C450

600mm INFILL BENCH

LEG STAND



C600
600mm Infill bench
with leg stand

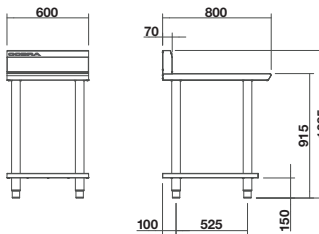

£950.00

C600

Model	Dimensions	Price (exc. VAT)
-------	------------	------------------

900mm INFILL BENCH

LEG STAND



C900
900mm Infill bench
with leg stand

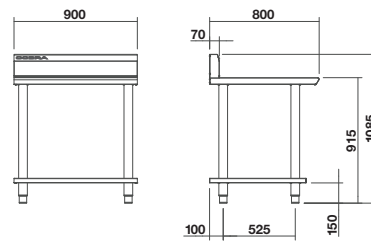

£1,070.00

C900

900mm INFILL BENCH

LEG STAND WITH SALAMANDER SUPPORT



C900S
900mm Infill bench with salamander
support on leg stand

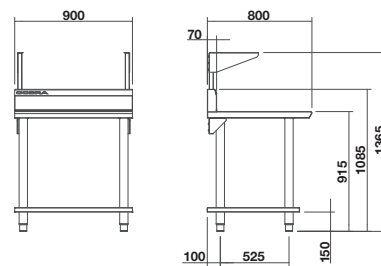

£1,540.00

C900S



20MSERIES

20DSERIES



Reduced footprints, better rack spacing and a bi-directional fan system.*

POWERFUL PERFORMANCE, SMALLER FOOTPRINT,

*E22 & E31D4 use single direction fans

turbofan[®]

TODAY'S INNOVATIVE, EASY TO USE TURBOFAN RANGE HAS BEEN DESIGNED AND MANUFACTURED TO THE HIGHEST SPECIFICATION AND CONTINUES TO PROVIDE A CLASS LEADING SOLUTION FOR EVERY KIND OF CATERING LOCATION. THESE EASY TO USE OVENS HAVE BEEN DESIGNED WITH A CLEAR UNDERSTANDING OF OUR CUSTOMERS NEEDS AND THE CHANGING DEMANDS OF THE CATERING INDUSTRY. DELIVERING OUTSTANDING COOKING, BAKING AND ROASTING PERFORMANCE, USING IMPROVED BI-DIRECTIONAL FAN SYSTEMS THAT ACHIEVE BETTER THAN EVER RESULTS

FEATURES...

- SPACE SAVING EFFICIENCY
- BI-DIRECTIONAL FAN SYSTEM
- DUAL BI-DIRECTIONAL FAN SYSTEM
- MORE OVENS, MORE APPLICATIONS
- PORTABLE COOKING
- FIELD REVERSIBLE SIDE HINGED DOORS
- SAFE TOUCH VENTED OVEN DOORS
- TOUCH SCREE MODULE
- DIGITAL CONTROL MODELS
- MARKET LEADING TRAY SPACING
- HALOGEN OVEN LAMPS
- MOISTURE INJECTION
- GRILL MODE
- SAFE TOUCH VENTED OVEN DOORS
- VITREOUS ENAMELLED OVEN CHAMBER

WWW.BLUE-SEAL.CO.UK

30DSERIES



The ultimate in commercial convection ovens - ideal for baking, roasting and holding.

PSERIES



Our upgraded range of easy to use Provers/ Holding Cabinets, are smart in design and even smarter in engineering, The eight or twelve tray units come with an auto-fill humidity generator and holding cabinet function mode as standard.

TSERIES



HSERIES



INNOVATIVE FEATURES... IN A CLASS OF ITS OWN.

20SERIES



E22T tray 460x330mm £65.00

Dimensions / Power (w x d x h)	Options	kw	Price (exc. VAT)
--------------------------------	---------	----	------------------

E22M3 MANUAL ELECTRIC CONVECTION OVEN

Rack capacity: 3
610mm x 608mm x 552mm
Electrical requirements:
230-240V, 50/60Hz,
1 Phase+N+E, 2.1kW, 9A
10A cordset supplied

3 x 460mm x 330mm half size sheet pan capacity 2.1
3 x 2/3 GN pan capacity
70mm Tray spacing
Compact 610mm width
3 Oven wire racks supplied
Single direction low-velocity fan
Double Stacking Kit DSK2223C

£1,870.00

£880.00



SK23 STAND £880.00
Stainless steel stand with castors
W 610mm x D 530mm x H 880mm



E22T tray 460x330mm £65.00

E23M3 MANUAL ELECTRIC CONVECTION OVEN

Rack capacity: 3
610mm x 642mm x 607mm
Electrical requirements:
230-240V, 50/60Hz,
1 Phase+N+E, 3.0kW, 12A
13A cordset fitted

3 x 460mm x 330mm half size sheet pan capacity 3.0
3 x 2/3 GN pan capacity
85mm Tray spacing
Compact 610mm width
3 Oven wire racks supplied
Bi-directional reversing fan system
Double Stacking Kit DSK2223C

£2,115.00

£880.00



SK23 STAND £880.00
Stainless steel stand with castors
W 610mm x D 530mm x H 880mm



E22T tray 460x330mm £65.00

E23D3 DIGITAL ELECTRIC CONVECTION OVEN

Rack capacity: 3
610mm x 642mm x 607mm
Electrical requirements:
230-240V, 50/60Hz,
1 Phase+N+E, 3.0kW, 12A
13A cordset fitted

3 x 460mm x 330mm half size sheet pan capacity 3.0
3 x 2/3 GN pan capacity
85mm Tray spacing
Compact 610mm width
3 Oven wire racks supplied
Bi-directional reversing fan system
Double Stacking Kit DSK2223C
Steam injection

£2,225.00

£880.00



SK23 STAND £880.00
Stainless steel stand with castors
W 610mm x D 530mm x H 880mm



E311GAST tray 1/1GN 20mm deep £65.00
E27FT tray 400x600mm £65.00
E32UST tray 460x660mm £65.00

E27M2 MANUAL ELECTRIC CONVECTION OVEN

Rack capacity: 2
810mm x 762mm x 607mm
Electrical requirements:
230-240V, 50/60Hz,
1 Phase+N+E, 3.0kW, 12A
13A cordset supplied

2 x 460mm x 660mm full size sheet pan capacity 3.0
2 x 600mm x 400mm tray capacity
85mm Tray spacing
Compact 810mm width
2 Oven wire racks supplied
Bi-directional reversing fan system
Double Stacking Kit DSK272831C

£2,420.00

£880.00



SK2731N STAND £880.00
Stainless steel stand with castors
Suits 600mm x 400mm trays and 1/1 GN pans
W 810mm x D 650mm x H 880mm



SK2731U STAND £880.00
Stainless steel stand with castors
Suits 660mm x 460mm pans
W 810mm x D 650mm x H 880mm

Dimensions / Power (w x d x h)	Options	kw	Price (exc. VAT)
-----------------------------------	---------	----	------------------

E27D2 DIGITAL ELECTRIC CONVECTION OVEN



Rack capacity: 2 810mm x 762mm x 607mm Electrical requirements: 230-240V, 50/60Hz, 1 Phase+N+E, 3.0kW, 12A 13A cordset supplied	2 x 460mm x 660mm full size sheet pan capacity 3.0 2 x 600mm x 400mm tray capacity 115mm Tray spacing Compact 810mm width 2 Oven wire racks supplied Bi-directional reversing fan system Double Stacking Kit DSK272831C Steam injection	£2,570.00
		£880.00

E311GAST tray 1/1GN 20mm deep	£65.00
E27FT tray 400x600mm	£65.00
E32UST tray 460x660mm	£65.00



SK2731N STAND	£880.00
Stainless steel stand with castors Suits 600mm x 400mm trays and 1/1 GN pans W 810mm x D 650mm x H 880mm	



SK2731U STAND	£880.00
Stainless steel stand with castors Suits 660mm x 460mm pans W 810mm x D 650mm x H 880mm	



E27M3 MANUAL ELECTRIC CONVECTION OVEN

Rack capacity: 3 810mm x 762mm x 607mm Electrical requirements: 230-240V, 50/60Hz, 1 Phase+N+E, 4.7kW, 19.6A No cordset supplied	3 x 460mm x 660mm full size sheet pan capacity 4.7 3 x 600mm x 400mm tray capacity 85mm Tray spacing Compact 810mm width 3 Oven wire racks supplied Bi-directional reversing fan system Double Stacking Kit DSK272831C	£2,735.00
		£880.00

E311GAST tray 1/1GN 20mm deep	£65.00
E27FT tray 400x600mm	£65.00
E32UST tray 460x660mm	£65.00



SK2731N STAND	£880.00
Stainless steel stand with castors Suits 600mm x 400mm trays and 1/1 GN pans W 810mm x D 650mm x H 880mm	



SK2731U STAND	£880.00
Stainless steel stand with castors Suits 660mm x 460mm pans W 810mm x D 650mm x H 880mm	



E27D3 DIGITAL ELECTRIC CONVECTION OVEN

Rack capacity: 3 810mm x 762mm x 607mm Electrical requirements: 230-240V, 50/60Hz, 1 Phase+N+E, 4.7kW, 19.6A No cordset supplied	3 x 460mm x 660mm full size sheet pan capacity 4.7 3 x 600mm x 400mm tray capacity 85mm Tray spacing Compact 810mm width 3 Oven wire racks supplied Bi-directional reversing fan system Double Stacking Kit DSK272831C Steam injection	£2,870.00
		£880.00

E311GAST tray 1/1GN 20mm deep	£65.00
E27FT tray 400x600mm	£65.00
E32UST tray 460x660mm	£65.00



SK2731N STAND	£880.00
Stainless steel stand with castors Suits 600mm x 400mm trays and 1/1 GN pans W 810mm x D 650mm x H 880mm	



SK2731U STAND	£880.00
Stainless steel stand with castors Suits 660mm x 460mm pans W 810mm x D 650mm x H 880mm	



E28M4 MANUAL ELECTRIC CONVECTION OVEN

Rack capacity: 4 810mm x 762mm x 662mm Electrical requirements: 230-240V, 50/60Hz, 1 Phase+N+E, 5.8kW, 25A No cordset supplied	4 x 460mm x 660mm full size sheet pan capacity 5.8 4 x 600mm x 400mm tray capacity 80mm Tray spacing Compact 810mm width 4 Oven wire racks supplied Twin Bi-directional reversing fans Double Stacking Kit DSK272831C	£3,695.00
		£880.00

E311GAST tray 1/1GN 20mm deep	£65.00
E27FT tray 400x600mm	£65.00
E32UST tray 460x660mm	£65.00



SK2731N STAND	£880.00
Stainless steel stand with castors Suits 600mm x 400mm trays and 1/1 GN pans W 810mm x D 650mm x H 880mm	



SK2731U STAND	£880.00
Stainless steel stand with castors Suits 660mm x 460mm pans W 810mm x D 650mm x H 880mm	



**Dimensions / Power
(w x d x h)**

Options

kw

Price (exc. VAT)

E28D4 | DIGITAL ELECTRIC CONVECTION OVEN

Rack capacity: 4
810mm x 762mm x 662mm
Electrical requirements:
230-240V, 50/60Hz,
1 Phase+N+E, 5.8kW, 25A
No cordset supplied

4 x 460mm x 660mm full size sheet pan capacity 5.6
4 x 600mm x 400mm tray capacity
80mm Tray spacing
Compact 810mm width
4 Oven wire racks supplied
Twin Bi-directional reversing fans
Double Stacking Kit DSK272831C
Steam injection

£4,015.00

£880.00

E311GAST tray 1/1GN 20mm deep £65.00
E27FT tray 400x600mm £65.00
E32UST tray 460x660mm £65.00



SK2731N STAND £880.00
Stainless steel stand with castors
Suits 600mm x 400mm trays and 1/1 GN pans
W 810mm x D 650mm x H 880mm



SK2731U STAND £880.00
Stainless steel stand with castors
Suits 660mm x 460mm pans
W 810mm x D 650mm x H 880mm



E931M | ELECTRIC CONVECTION OVEN & 4 ELEMENT COOKTOP

675mm x 626mm x 800mm
Cooktop
Single phase
2 x 2kW front and 2 x 1.5kW
rear hot plate elements.

7

£4,305.00

Convection Oven
Rack capacity: 4
Electrical requirements:
230-240V, 50/60Hz,
1 Phase+N+E, 3.1kW, 12.9A
13A cordset supplied

4 x 1/1 GN tray capacity
80mm Tray spacing
Digital display time and temperature controls
4 Oven wire racks supplied
Single directional low-velocity fan
* Two separate electrical supplies

3.0

30SERIES



E30M3 | MANUAL ELECTRIC CONVECTION OVEN

Rack capacity: 3
810mm x 616mm x 625mm
Electrical requirements:
230-240V, 50/60Hz,
1 Phase+N+E, 2.3kW, 9.5A
13A cordset supplied

3 x 1/1 GN tray capacity
100mm Tray spacing
Analogue time and temperature controls
3 Oven wire racks supplied
Single directional low-velocity fan
Double Stacking Kit DSK272831C

2.3

£2,010.00

£880.00

E311GAST tray 1/1GN 20mm deep £65.00



SK2731N STAND £880.00
Stainless steel stand with castors
1/1 GN pans
W 810mm x D 650mm x H 880mm



E31D4 | DIGITAL ELECTRIC CONVECTION OVEN

Rack capacity: 4
810mm x 616mm x 625mm
Electrical requirements:
230-240V, 50/60Hz,
1 Phase+N+E, 3.1kW, 12.9A
13A cordset supplied

4 x 1/1 GN tray capacity
80mm Tray spacing
Digital display time and temperature controls
Grill mode
4 Oven wire racks supplied
Single directional low-velocity fan
Double Stacking Kit DSK272831C

3.1

£2,800.00

£880.00

E311GAST tray 1/1GN 20mm deep £65.00



SK2731N STAND £880.00
Stainless steel stand with castors
1/1 GN pans
W 810mm x D 650mm x H 880mm

Dimensions / Power
(w x d x h)

Options

kw

Price (exc. VAT)



E33D5 | DIGITAL CONVECTION OVEN

Rack capacity: 5
610mm x 680mm x 730mm

Electrical requirements:
230-240V, 50Hz,
1 Phase+N+E, 6kW, 25.7A
No cordset supplied

5 x 1/1 GN Tray capacity
85mm Tray spacing
Digital time and temperature controls
Bi-directional fan
2 speed fan
3 stage cooking function
5 levels of humidity
Optional core temp probe
Double Stacking Kit DSK33C
Oven racks not supplied

6 £4,170.00

E311GAST tray 1/1GN 20mm deep £65.00
Oven rack p/no. 236057 £55.00
240550 Heat Shield £245.00

SK33 STAND £880.00
Stainless steel stand with castors
W 610mm x D 650mm x H 880mm



E33T5 | TOUCH SCREEN ELECTRIC CONVECTION OVEN

Rack capacity: 5
610mm x 680mm x 730mm

Electrical requirements:
230-240V, 50Hz,
1 Phase+N+E, 6kW, 25.7A
No cordset supplied

5 x 1/1 GN Tray capacity
85mm Tray spacing
Touch screen controls
Bi-directional fan
2 speed fan
3 stage cooking function
5 levels of humidity
Optional core temp probe
Double Stacking Kit DSK33C
Oven racks not supplied

6 £6,315.00

E311GAST tray 1/1GN 20mm deep £65.00
Oven rack p/no. 236057 £55.00
240550 Heat Shield £245.00



SK33 STAND £880.00
Stainless steel stand with castors
W 610mm x D 650mm x H 880mm



E32D4 | DIGITAL ELECTRIC CONVECTION OVEN

Rack capacity: 4
735mm x 810mm x 730mm

Electrical requirements:
230-240V, 50/60Hz,
1 Phase+N+E, 6.5kW, 27A
No cordset supplied

4 x 460mm x 660mm full size sheet pan capacity 6.5
4 x 600mm x 400mm tray capacity
110mm Tray spacing
Compact 735mm width
4 Oven wire racks supplied
Bi-directional fan motor
3 stage cooking function
5 levels of humidity setting
2 speed bi-directional reversing fan system
Double Stacking Kit DSKE32C
Optional core temp probe
Steam injection

£4,960.00

E32UST tray 460x660mm £65.00
240466 Heat Shield £260.00



SK32 STAND £880.00
Stainless steel stand with castors
W 735mm x D 650mm x H 880mm



E32T4 | TOUCH SCREEN ELECTRIC CONVECTION OVEN

Rack capacity: 4
735mm x 810mm x 730mm

Electrical requirements:
230-240V, 50/60Hz,
1 Phase+N+E, 6.5kW, 27A
No cordset supplied

4 x 460mm x 660mm full size sheet pan capacity 6.5
4 x 600mm x 400mm tray capacity
110mm Tray spacing
Compact 735mm width
4 Oven wire racks supplied
Bi-directional fan motor
3 stage cooking function
5 levels of humidity setting
2 speed bi-directional reversing fan system
Double Stacking Kit DSKE32C
Optional core temp probe
Steam injection

£5,725.00

E32UST tray 460x660mm £65.00
240466 Heat Shield £260.00



SK32 STAND £880.00
Stainless steel stand with castors
W 735mm x D 650mm x H 880mm

Dimensions / Power (w x d x h)	Options	kW	Price (exc. VAT)
-----------------------------------	---------	----	------------------



G32D4 | DIGITAL GAS CONVECTION OVEN

Rack capacity: 4 735mm x 810mm x 910mm	4 x 460mm x 660mm full size sheet pan capacity 1 phase 4 x 600mm x 400mm tray capacity 110mm Tray spacing Compact 735mm width 4 Oven wire racks supplied Bi-directional fan motor Double Stacking Kit DSKG32C Steam injection Optional core temp. probe		£6,065.00
Electrical requirements: 230-240V, 50/60Hz, 1 Phase+N+E, 0.5A 10A cordset fitted			£1,105.00
Gas requirements: 35 MJ/hr burner rating. Natural, Propane/Butane models Unit supplied complete with gas type conversion kit Gas connection 1/2" NPT male 10kW equivalent gas power			£275.00
		SK32 STAND Stainless steel stand with castors W 735mm x D 650mm x H 880mm	£880.00



E32UST tray 460x660mm	£65.00
240549 Heat Shield	£275.00



E35D6 | FULL SIZE DIGITAL / ELECTRIC CONVECTION OVEN

W 910mm x D 1022mm x H 871mm including 76mm feet	12.5	£8,940.00
<ul style="list-style-type: none"> • 6 406mm x 736mm / 16" x 29" tray capacity • 6 457mm x 762mm / 18" x 30" tray capacity • 105mm tray spacing • 12kW heating power • Electronic controls with Digital Time and Temperature display • Optional M236060 Core Temperature Probe Kit • Stand SK35 • Stacking Kit DSK35 		£275.00
		£1,200.00
		£1,055.00

E35GBT tray 460x760mm	£65.00
-----------------------	--------

PROVER / HOLDING CABINETS

PSERIES PROVER/HOLDING CABINETS

STANDARD FEATURES

P8M / P10M / P12M

- Dual function prover and holding cabinet
- Designed for individual use or system installed with Turbofan 32D convection ovens
- Low velocity circulation fan system
- Humidity level control
- Compact 735mm width
- Full double skin construction
- Auto water fill system with optional integrated water filter kit

P8M

- 8 Full size sheet pan capacity
- 8 EN 600 x 400 tray capacity

P12M

- 12 Full size sheet pan capacity
- 12 EN 600 x 400 tray capacity

- Continuous door seal
- Side hinged door
- Off / Prove / Hold mode selection
- Mechanical thermostat 20-85°C
- Dual halogen cabinet interior lamps
- Cabinet temperature display thermometer
- 4 dia. 76mm castors with 2 front castors dual wheel and swivel lock, 2 rigid rear castors
- 100% recyclable packaging

- 16 Half size sheet pan capacity
- 76mm Tray spacing

- 24 Half size sheet pan capacity
- 74mm Tray spacing

OPTIONAL EXTRAS

234347 Filter Head Kit	£300.00
This kit supplies the cartridge mounting head assembly plus all associated plumbing/fittings for installation to P12 provers. Also includes double check/pressure reducing valve and 2 metres of tubing for connection to supply.	
234562 Filter Cartridge P124BN CUNO	£235.00
Filter cartridge itself, for connection to above installation kit.	



P8M | AUTO ELECTRIC PROVER & HOLDING CABINET

Rack capacity: 8 735mm x 810mm x 914mm Electrical requirements: 230-240V, 50/60Hz, 1 Phase+N+E, 1.5kW, 6.3A 10A cordset fitted	Dual function prover and holding cabinet Designed for individual use or system installed with Turbofan 32D convection ovens 8 Full size sheet pan capacity 16 Half size sheet pan capacity 8 EN 600 x 400 tray capacity P/No. 235445 76mm Tray spacing Compact 735mm width	1.5	£4,650.00
			£495.00
	P/No. 234841 Stacking Kit to E32D4		£165.00



Dimensions / Power (w x d x h)	Options	kw	Price (exc. VAT)
P10M	AUTO ELECTRIC PROVER & HOLDING CABINET		

Rack capacity: 10
610mm x 680mm x 1015mm
Electrical requirements:
230-240V, 50/60Hz,
1 Phase+N+E, 1.5kW, 6.3A
10A cordset supplied

Dual function prover and holding cabinet
Designed for individual use or
system installed with Turbofan E33D
convection oven
10 1/1 GN pan capacity
74mm Tray spacing
Compact 610mm width

1.5 £4,095.00

P/No. 236617 Stacking Kit to E33D5

£165.00



P12M	AUTO ELECTRIC PROVER & HOLDING CABINET		
-------------	---	--	--

Rack capacity: 12
735mm x 810mm x 1129mm
Electrical requirements:
230-240V, 50/60Hz,
1 Phase+N+E, 1.9kW, 8.5A
10A cordset supplied

Dual function prover and holding cabinet
Designed for individual use or
system installed with Turbofan 32D
convection ovens
12 Full size sheet pan capacity
24 Half size sheet pan capacity
12 EN 600 x 400 tray capacity
74mm Tray spacing
Compact 735mm width

1.9 £5,110.00

£565.00

P/No. 234841 Stacking Kit to E/G32D4

£165.00



P85M8	PROVER/HOLDING CABINET		
--------------	-------------------------------	--	--

W 910mm x D 880mm x H 914mm including dia. 76mm castors
• 8 457mm x 762mm / 18" x 30" tray capacity
• 76mm tray spacing
• 1.5kW heating power
• Optional M236060 Core Temperature Probe Kit
• Stacking kit 239704 P85M8 with E35D6

1.5 £4,650.00

£275.00

£165.00

P85M8



P85M12	PROVER/HOLDING CABINET		
---------------	-------------------------------	--	--

W 910mm x D 810mm x H 1129mm including dia. 76mm castors
• 12 457mm x 762mm / 18" x 30" tray capacity
• 74mm tray spacing
• 1.9kW heating power
• Optional M236060 Core Temperature Probe Kit
• Stacking kit 239704 P85M12 with E35D6

1.9 £5,110.00

£275.00

£165.00

P85M12



H8D-UC

MODEL	DETAILS	Gas Power kW	Price (exc. VAT)
H8D-UC	HOLDING CABINET		
	W 610mm x D 680mm x H 810mm • 8 x 1/1 GN tray capacity • 74mm tray spacing • 1.2kW heating power • Electronic touch sensitive control panel	1.2	£4,440.00



H8D-FS-UC

H8D-FS-UC	HOLDING CABINET		
	W 735mm x D 810mm x H 810mm • 8 full size 460mm x 660mm / 18" x 26" sheet pan capacity • 74mm tray spacing • 1.9kW heating power • Electronic touch sensitive control panel	1.9	£4,555.00



H10D-FS

H10D-FS	HOLDING CABINET		
	W 735mm x D 810mm x H 1015mm • 10 full size 460mm x 660mm / 18" x 26" sheet pan capacity • 74mm tray spacing • 1.9kW heating power • Electronic touch sensitive control panel	1.9	£4,795.00



H10D

H10D	HOLDING CABINET		
	W 610mm x D 1015mm x H 680mm • 10 1/1 GN pan capacity • 74mm tray spacing • 1.2kW heating power • Electronic touch sensitive control panel	1.2	£4,580.00



EHT10-L

EHT10-L	TOUCH SCREEN ELECTRIC HUMIDIFIED HOLDING CABINET		
	W 610mm x D 680mm x H 1015mm • 10 1/1 GN pan capacity • 2.3kW heating power • Electronic touch sensitive control panel	2.3	£6,020.00

OPTIONAL EXTRAS

SKEHT10	Stainless steel stand with castors (2 with swivel lock) to suit EHT10-L model W610mm x D 727mm x H 609mm	£625.00
237472	Double stacking kit to suit E33/EHT10-L models	£205.00
234347	Filter head kit This kit supplies the cartridge mounting head assembly plus all associated plumbing/fittings for installation to P8/P12/P10/P85 probers. Also includes double check/pressure reducing valve and 2 metres of tubing for connection to supply	£300.00
234562	Filter Cartridge P124BN CUNO Filter cartridge itself for connection to above installation kit	£235.00

Model	Details	Price (exc. VAT)
-------	---------	------------------

VH SERIES



VH32

VH32 VENTLESS HOOD FOR E32D4/E32T4 OVENS

- W 742mm x D 1015mm x H 340mm
- 230-240V, 50/60Hz, 1 Phase+N+E, 0.5A
- 10A plug cordset fitted

£5,890.00



VH33

VH33 VENTLESS HOOD FOR E33D5/E33T5 OVENS

- W 617mm x D 890mm x H 340mm
- 230-240V, 50/60Hz, 1 Phase+N+E, 0.5A
- 10A plug cordset fitted

£5,735.00



VH35-30

VH35-30 VENTLESS HOOD FOR E35D6-30/E35T6-30 OVENS

- W 917mm x D 1145mm x H 340mm
- 230-240V, 50/60Hz, 1 Phase+N+E, 1.0A
- 10A plug cordset fitted

£6,765.00

STANDARD FEATURES

- Ventless oven hood - no vent connection or canopy required
- 3-stage filtering with condensing heat exchanger; 1st stage grease filter baffle, 2nd stage mesh particle filter, 3rd stage odour reduction charcoal filter
- Oven vent condensing heat exchanger reducing heat emissions
- Condensate collection to self-contained collection pan
No waste drain connection needed or condensate collection to waste drain. No manual emptying of condensate collection pan required

- Hood control interlock with oven - cannot operate without hood opening
- Low speed fan operation - reduced noise
- Automatic high speed fan when oven door is open
- User replacement charcoal filter
- Removable grease baffle and mesh filters
- 240V, 10A plug cordset electrical connection
- Hood installation kits are required to install VH Series hoods on Turbofan ovens

turbofan[®]

COMBI

Turbofan Combi Steamers offer the ultimate in convenience, versatility and control, enabling you to deliver a wide range of foods to the highest standards without the need for large appliances.

From bread and pizza, through seafood, meats and vegetables to dessert, Turbofan Combi provides convection, steam or combination convection/steam cooking, with a choice of manual or digital models.

With refined lines and sophisticated design the entirely flat 40 Series lets you make the most of your space, be it behind the scenes or out in front of the crowd. Tuck it away in the bar area or have it pride of place in the open kitchen – either way you'll be happy to see this high performer deliver the goods time and time again.

- Choice of 6 models – 3 digital and 3 manual
- 7kW – 14kW heating power
- 30 – 80 covers per load
- 70mm tray spacing
- 5, 7 or 10 tray capacity
- 600mm x 400mm trays
- Range of accessories and options

MANUAL



EC40M5



EC40M7



EC40M10

DIGITAL



EC40D5



EC40D7



EC40D10

	Model	Hob Options	Dimensions	Gas Power kW	Price (exc. VAT)
	EC40M5		5 TRAY MANUAL ELECTRIC COMBI OVEN		
			W 777mm x D 835mm x H 777mm	7	£6,095.00
			<ul style="list-style-type: none"> • 5 x 1/1 GN tray capacity • 5 x 600mm x 400mm tray capacity • 70mm tray spacing • 7.25kW heating power • 30 covers per load • Electromechanical controls • Supplied with water softener 		
			Stand SK40A		£880.00
			3.64.0029 Stainless Steel Wire Oven Grid 1/1 GN		£80.00
	EC40D5		5 TRAY DIGITAL ELECTRIC COMBI OVEN		
			W 777mm x D 835mm x H 777mm	7	£8,120.00
			<ul style="list-style-type: none"> • 5 x 1/1 GN tray capacity • 5 x 600mm x 400mm tray capacity • 70mm tray spacing • 7.25kW heating power • 30 covers per load • 2.4" LCD-TFT colour display with rapid selection scroller • Automatic cleaning system • Optional multipoint core temperature probe CP004 • Supplied with water softener 		£375.00
			Stand SK40A		£880.00
			3.64.0029 Stainless Steel Wire Oven Grid 1/1 GN		£80.00
	EC40M7		7 TRAY MANUAL ELECTRIC COMBI OVEN		
			W 777mm x D 835mm x H 942mm	12	£7,535.00
			<ul style="list-style-type: none"> • 7 x 1/1 GN tray capacity • 7 x 600mm x 400mm tray capacity • 70mm tray spacing • 12.5kW heating power • 50 covers per load • 2.4" LCD-TFT colour display with rapid selection scroller • Supplied with water softener 		
			Stand SK40A		£880.00
			3.64.0029 Stainless Steel Wire Oven Grid 1/1 GN		£80.00
	EC40D7		7 TRAY DIGITAL ELECTRIC COMBI OVEN		
			W 777mm x D 835mm x H 942mm	12	£9,710.00
			<ul style="list-style-type: none"> • 7 x 1/1 GN tray capacity • 7 x 600mm x 400mm tray capacity • 70mm tray spacing • 12.5kW heating power • 50 covers per load • 2.4" LCD-TFT colour display with rapid selection scroller • Automatic cleaning system • Optional multipoint core temperature probe CP004 • Supplied with water softener 		£375.00
			Stand SK40A		£880.00
			3.64.0029 Stainless Steel Wire Oven Grid 1/1 GN		£80.00
	EC40M10		10 TRAY MANUAL ELECTRIC COMBI OVEN		
			W 777mm x D 835mm x H 1152mm	14	£8,455.00
			<ul style="list-style-type: none"> • 10 x 1/1 GN tray capacity • 10 x 600mm x 400mm tray capacity • 70mm tray spacing • 14.5kW heating power • 80 covers per load • Electromechanical controls • Supplied with water softener 		
			Stand SK40-10A		£880.00
			3.64.0029 Stainless Steel Wire Oven Grid 1/1 GN		£80.00

Dimensions / Power (w x d x h)	Standard Features	Optional Extras	Price (exc. VAT)
-----------------------------------	-------------------	-----------------	---------------------



EC40D10

EC40D10 | 10 TRAY DIGITAL ELECTRIC COMBI OVEN ⚡

W 777mm x D 835mm x H 1152mm	14	£10,645.00
<ul style="list-style-type: none"> • 10 x 1/1 GN tray capacity • 10 x 600mm x 400mm tray capacity • 70mm tray spacing • 14.5kW heating power • 80 covers per load • 2.4" LCD-TFT colour display with rapid selection scroller • Automatic cleaning system • Optional multipoint core temperature probe CP004 • Supplied with water softener 		£375.00
Stand SK40-10A		£880.00
3.64.0029 Stainless Steel Wire Oven Grid 1/1 GN		£80.00

Model nos	Description	
DSK405 Stacking kit	5 grid on 5 grid 5 grid on 7 grid	£880.00
DSS405 Stand for 5 grid stacking kit	stand on 5 for 5	£340.00
DSK407 Stacking kit	7 grid on 7 grid	£880.00
DSS405 required for 5 grid on 5 grid only, 5 grid on 7 grid on 7 grid stands on floor on unit feet.		
Air cooled condensing hoods available on all models, factory fit only 4 week delivery from date of order.		
IKKV51 plus NPK configuration total list price		£3,290.00
Opposite hinge door (factory fit only)		£170.00
CDL05 Detergent cartridge 5ltr for auto wash units		£120.00

PIZZA & BAKERY EQUIPMENT

Dimensions / Power (w x d x h)	Options	kw	Price (exc. VAT)
-----------------------------------	---------	----	------------------



430/DS-M | ELECTRIC PIZZA OVEN

Dimensions: mm (w x d x h)
 External 950 x 950 x 400
 Internal 630 x 630 x 150
 Net weight: 94kg
 Single Phase

430/DS-M electric pizza oven
 Pizza capacity: 4 x 12 inch pizzas per deck.

4.4 £2,260.00

BSPZ01 £880.00
 Steel stand with adjustable feet
 W 950mm x D 950mm x H 900mm



830/DS-M | ELECTRIC PIZZA OVEN

Dimensions: mm (w x d x h)
 External 950 x 950 x 730
 Internal 630 x 630 x 150
 (per deck)
 Net weight: 158kg
 Single Phase
 2 x 4.4kW electrical supplies

830/DS-M electric pizza oven
 Pizza capacity: 4 x 12 inch pizzas per deck.

8.8 £3,580.00

BSPZ01 £880.00
 Steel stand with adjustable feet
 W 950mm x D 950mm x H 900mm



BM10 | PLANETARY MIXER

Dimensions: mm (w x d x h)
 400 x 450 x 630 (stand foot print)
 Capacity 10 litres
 Net weight: 62kg

10 litre mixer

3 £2,170.00



BM20 | HEAVY DUTY MIXER

Dimensions: mm (w x d x h)
 515 (incl. handle) x 518 x 879
 Capacity 20 litres
 Net weight: 98kg

20 litre mixer

3 £3,025.00

WARE WASHING EQUIPMENT



SG4E2

GLASS WASHER



Dimensions: mm (w x d x h)
 External w460 x d521 x h680
 400mm x 400mm rack size
 Includes rinse aid detergent and drain pumps

2.66w

£2,165.00

Pedestal stand

£310.00



SG45E2

GLASS WASHER



Dimensions: mm (w x d x h)
 External w530 x d600 x h755
 450mm x 450mm rack size
 Includes rinse aid detergent and drain pumps

3.78w

£3,015.00

Pedestal stand

£420.00



SG5EC2

GLASS WASHER



Dimensions: mm (w x d x h)
 External w600 x d600 x h820
 500mm x 500mm rack size
 Includes rinse aid detergent and drain pumps

3.78w

£2,860.00

Pedestal stand

£420.00



SD5EC2

DISH WASHER



Dimensions: mm (w x d x h)
 External w600 x d600 x h820
 500mm x 500mm rack size
 Includes rinse aid detergent and drain pumps

3.78w

£2,860.00

Pedestal stand

£420.00



SD5ECBT2

DISH WASHER



Dimensions: mm (w x d x h)
 External w600 x d600 x h820
 500mm x 500mm rack size
 Includes rinse aid detergent and drain pumps

6.45w

£3,460.00

Pedestal stand

£420.00

Class 'A' air gap breaktank model

WARE WASHING EQUIPMENT



Dimensions / Power (w x d x h)	Options	kw	Price (exc. VAT)
SH55E BT HIGH VOLUME HOOD WASHER			
Dimensions: mm (w x d x h) External 710 x d735 x h1450 Lowered 1860 raised.	SH55E high volume hood washer single phase SH55E high volume hood washer 3 phase 55068 Stainless steel wings	6.75 10	£5,315.00 £5,315.00 £400.00 (each)
Features: Twin wash cycle and integral break tank. Rack output: 30 per hour	* Model Includes rinse aid detergent and drain pumps.		



Dimensions / Power (w x d x h)	Options	kw	Price (exc. VAT)
SH120E BT HIGH VOLUME HOOD WASHER			
Dimensions: mm (w x d x h) External 710 x 740 x 1450 lowered 1860 raised.	SH120E high volume hood washer (three phase only) 55068 Stainless steel wings	10.1	£6,635.00 £400.00 (each)
Features: Class "A" Air Gap, integral break tank and has three wash programmes. Basket size: 500mm. Washing capacity: up to 1200 plates per hour	* Model Includes rinse aid detergent and drain pumps.		



WATER SOFTENERS			Price (exc. VAT)
Brita Aquaquell Purity 600 Complete System With MCU Display			£1,565.00
Manual water softeners	WS08	8	£255.00
	WS12	12	£285.00
	WS16	16	£365.00

DEFINITIONS

- 1.1 "The Company" -means Blue Seal Limited, a subsidiary of Moffat Group Pty Limited
- 1.2 "Confidential Information" – all information in respect of the business of the Company including know-how and other matters connected with the Goods, information concerning the Company's relationships with actual or potential clients, customers or suppliers and the needs and requirements of the Company and of such persons and any other information which, if disclosed, will be liable to cause harm to the Company
- 1.3 "The Contract" - means any contract for the sale of Goods by the Company to the Customer on the terms and conditions set out in this document
- 1.4 "The Customer" - means the customer of the Company
- 1.5 "The Goods" - means any Unit Items and/or Spares forming the subject of this Contract including parts and components of or materials incorporated in them as set out in Customer's order
- 1.6 "Force Majeure Event" - means any event beyond a party's reasonable control, which by its nature could not have been foreseen, or, if it could have been foreseen, was unavoidable, including strikes, lock-outs or other industrial disputes (whether involving its own workforce or a third party's), failure of energy sources or transport network, acts of God, war, terrorism, riot, civil commotion, interference by civil or military authorities, national or international calamity, armed conflict, malicious damage, breakdown of plant or machinery, nuclear, chemical or biological contamination, sonic boom, explosions, collapse of building structures, fires, floods, storms, earthquakes, loss at sea, epidemics or similar events, natural disasters or extreme adverse weather conditions, or default of suppliers or subcontractors
- 1.6 "The Prices" – means the prices set out in the Company's quotation for the relevant Goods
- 1.7 "Spares" – means replacement components which are integral to the running performance of Unit Items
- 1.8 "Unit Items" – means large, capital pieces of equipment, such as convection ovens which are detailed from time to time in the Company's catalogues

QUOTATION

- 2. Quotations by the Company unless otherwise stated in them shall be valid for a period of 30 days only from the date of the quotation, provided the Company has not previously withdrawn it.

EXISTENCE OF CONTRACT

- 3.1 Each order or acceptance of a quotation for Goods will be deemed to be an offer by the Customer to purchase Goods upon these terms and conditions. The Contract is formed when the Customer's order (however given) is accepted by the Company by the earliest of (a) the Company's written acceptance (b) delivery of the Goods or (c) the Company's invoice.
- 3.2 The Contract will be upon these terms and conditions to the exclusion of all other terms and conditions, including any terms or conditions which the Customer purports to apply under any purchase order, confirmation of order or similar document, whether or not such document is referred to in the Contract.
- 3.3 No variations or amendments of this Contract shall be binding on the Company unless confirmed by it in writing.

PRICES

- 4.1 Prices for:
 - 4.1.1 Spares are ex-works and include insurance, but exclude value added tax and any other similar or equivalent taxes, duties, fees and levies imposed from time to time by any government or other authority) which will be payable in addition to that sum in the manner and at the rate prescribed by law from time to time. For the avoidance of doubt, the Customer will be responsible for the costs relating to carriage and delivery in addition to the Prices, and details of the applicable delivery charges will be set out in the relevant order, and shall be dependent on the particular delivery service required by the Customer. The Company reserves the right to vary the costs of delivery (including, without limitation, the delivery services offered to a Customer) at any time prior to acceptance of an order pursuant to clause 3.1 above.
 - 4.1.2 Unit Items are inclusive of the Company's standard delivery charges (as may be varied from time to time) and insurance, but exclude value added tax and any other similar or equivalent taxes, duties, fees and levies imposed from time to time by any government or other authority, which will be payable in addition to that sum in the manner and at the rate prescribed by law from time to time. The Customer may request that Unit Items are delivered via an expedited service, and the Company reserves the right to charge an expedited delivery charge in such instances. Details of any such charge shall be notified to the Customer in advance.
 - 4.1.3 In the event that the Customer orders a combination of both Spares and Unit Items, the Spares will be delivered as part of the Unit Items order at no additional cost, save where otherwise agreed with the Customer.

PAYMENT

- 5.1 All invoices for the Prices for the Goods and any carriage and delivery costs payable by the Customer in addition to the Prices are payable by the Customer without discount of any kind in pounds sterling on or before the date stated on the Company's invoice at the Company's premises stated on the invoice and in no circumstances shall the Customer be entitled to make any deduction or withhold payment for any reason at all.
- 5.2 Time for payment shall be of the essence of the Contract. Without prejudice to any other rights of the Company, if the Customer fails to pay the invoice price by the due date, the Customer shall pay interest on any overdue amount from the date on which payment was due to that on which it is made (whether before or after judgment) at the rate prescribed in the Late Payment of Commercial Debts (Interest) Act 1998 and reimburse to the Company

- all the costs and expenses (including legal costs) incurred in the collection of any overdue amount.
- 5.3 All payments will be made in cleared funds by the Customer in accordance with the provisions of clause 5.1 above. Payment may be made by cheque, BACS, credit and/ or debit card or by cash.
- 5.4 Without prejudice to condition 5.2, if the Customer fails to make any payment due to the Company under the Contract on or before the due date the Company will be entitled to withhold further supply of Goods until payment of all overdue sums has been made and to cancel any or all orders accepted under condition 3.1 which have not yet been delivered.
- 5.5 Following termination of the Contract:
 - 5.5.1 the Company will be entitled to invoice all Prices and any carriage and delivery costs incurred which have not yet been invoiced; and
 - 5.5.2 all invoices (including any invoices issued under condition 5.5.1) will become immediately due and payable by the Customer.

TITLE

- 6.1 Notwithstanding the earlier passing of risk in accordance with condition 7, title in the Goods shall remain with the Company and shall not pass to the Customer until the amount due under the invoice for such Goods has been paid in full cleared funds.
- 6.2 Until the title of the Goods passes to the Customer, the Customer shall:
 - 6.2.1 hold the Goods as bailee for the Company;
 - 6.2.2 shall store (at no cost to the Company) or mark them so they can at all times be identified as the Goods of the Company;
 - 6.2.3 maintain the Goods in a satisfactory condition;
 - 6.2.4 keep the Goods insured for their full price against all risks to the reasonable satisfaction of the Company and whenever requested by the Company produce a copy of the policy of insurance to the Company.
- 6.3 The Company shall, by giving the Customer written notice, be entitled at any time before title passes to repossess and use or sell all or any of the Goods and so terminate (without any liability to the Customer) the Customer's right to use, sell or otherwise deal in them and for that purpose, or determining what if any Goods are held by the Customer and inspecting them, to enter any premises of the Customer.
- 6.4 Until title passes, the Customer may use and resell the Goods in the ordinary course of its business before ownership has passed to it, provided that the Customer will be permitted to make sales solely on the following conditions:
 - 6.4.1 any sale will be effected at full market value;
 - 6.4.2 any sale will be a sale of the Customer's property on the Customer's own behalf and the Customer will deal as principal when making such a sale;
 - 6.4.3 the Customer will hold such part of the proceeds of sale as represents the amount owed by the Customer to the Company in trust for the Company and will account to the Company accordingly; and
 - 6.4.4 the Customer will include a retention of title clause in its sale contract with its customer.

RISK, DELIVERY AND PERFORMANCE

- 7.1 Risk of damage to or loss of the Goods passes when they are delivered to the Customer
- 7.2 Goods are delivered to the Customer by the Company when the Company makes them available to the Customer or any agent of the Customer or any carrier (who shall be the Customer's agent whoever pays his charges) at the Customer's premises or other delivery point agreed by the Company.
- 7.3 The Company may at its discretion deliver the Goods by instalments in any sequence
- 7.4 Where the Goods are delivered by instalments, each instalment shall be deemed to be the subject of a separate Contract and no default or failure by the Company in respect of any one or more instalments shall vitiate the Contract in respect of the Goods previously delivered or undelivered Goods.
- 7.5 The Company may deliver to the Customer and the Customer shall accept in satisfaction of the Contract a lesser number than the number of Goods ordered. In such circumstances, the Customer will only pay the Prices for those Goods which have been delivered.
- 7.6 The Company will use reasonable endeavours to deliver the Goods within the time agreed with the Customer and notified to the Customer within the Company's acceptance of the Customer's order, and, if no time is agreed, then within a reasonable time, but the time of delivery in all circumstances will not be of the essence. If, despite those endeavours, the Company is unable for any reason to fulfil any delivery on the specified date or within a reasonable time, the Company will be deemed not to be in breach of this Contract. Any delay in delivery will not entitle the Customer to cancel the order unless and until the Customer has given 30 days' written notice to the Company requiring the delivery to be made and the Company has not fulfilled the delivery within that period. If the Customer cancels the order in accordance with this condition 7.6 then the Company will refund to the Customer any sums which the Customer has paid to the Company in respect of that order or part of the order which has been cancelled. Subject to condition 10, this condition contains the full extent of the Company's liability for a failure to comply with this condition.
- 7.7 If the Customer fails to take delivery of the Goods or any part of them on the due date and fails to provides any instructions, documents, licenses, consents or authorisations required to enable the Goods to be delivered, the Goods will be deemed to have been delivered on the due date and (without prejudice to its other rights) the Company shall be entitled upon giving written notice to the Customer to:
 - 7.7.1 store or arrange for the storage of the Goods, until actual delivery or sale in accordance with condition 7.7.2 and charge the Customer for all related costs and expenses including storage and insurance;
 - 7.7.2 sell any of the Goods at the best price reasonably obtainable in the circumstances and charge the Customer for any shortfall below the price under the Contract or account to the Customer for any excess achieved over the price under the Contract, in both cases having taken into account any charges related to the sale

over the price under the Contract, in both cases having taken into account any charges related to the sale.

7.8 Notwithstanding the fact that no right to cancel is provided to a Customer other than as expressly provided for in condition 7.6 above, where the Customer does cancel an Order, other than in accordance with the provisions of clause

7.6 the Company reserves the right to charge the Customer a fee (including without limitation a re-stocking fee) to reflect the actual losses suffered by the Company in connection with such cancellation.

CLAIMS NOTIFICATION

8.1 Any claim for non-delivery of any Goods shall be notified in writing by the Customer to the Company within 7 days of the date of the Company's invoice

8.2 Any claim that Goods have been delivered damaged are not of the correct quantity or do not comply with their description shall be notified by the Customer to the Company within 3 days of their delivery.

8.3 Any alleged defect shall be notified by the Customer to the Company within 3 days of the delivery of the Goods or in the case of any defect which is not reasonably apparent on inspection within 7 days of the defect coming to the Customer's attention and in any event within 1 month from the date of delivery

8.4 Any claim under this condition must be in writing and must contain full details of the claim including part numbers of any allegedly defective Goods

8.5 The Company shall be afforded reasonable opportunity and facilities to investigate any claims made under this condition and the Customer shall if so requested in writing by the Company promptly return any Goods the subject of any claim and any packing securely packed and carriage paid to the Company for examination.

8.6 The Company shall have no liability with regard to any claim in respect of which the Customer has not complied with the provisions of this condition.

SCOPE OF CONTRACT

9.1 The Company will, free of charge, within a period of 12 months from the date of delivery of Goods which are proved to the reasonable satisfaction of the Company to be defective due to defects in material or workmanship, at its option, repair or replace such Goods or allow the Customer to return the Goods and give them credit for their invoice value of such Goods. This obligation will not apply and under no circumstances shall the Company have any liability of whatever kind:

9.1.1 for any defects resulting from wear and tear accident improper use by the Customer or use by the Customer otherwise than in accordance with the instructions or advice of the Company or neglect or from any instructions or materials provided by the Customer;

9.1.2 for any Goods which have been adjusted modified or repaired otherwise than by the Company save by way of necessary warranty work carried out by the Customer on the authority of the Company

9.1.3 for the suitability of any Goods for any particular purpose or use under specific conditions, whether or not the purpose or conditions were known or communicated to the Company;

9.1.4 for any descriptions, illustration, specifications, figures as to performance, drawings and particulars of weights and dimensions submitted by the Company contained in the Company's catalogues, price lists or elsewhere since they are merely intended to represent a general idea of the Goods and not to form part of the Contract or be treated as representations;

9.1.5 for any technical information recommendations statements or advice furnished by the Company its servants or agents not given in writing in response to a specific written request from the Customer before the Contract is made;

9.1.6 for any variations in the quantities or dimensions of any Goods or changes of their specifications or substitution of any materials or components, if the variation or substitution does not materially affect the characteristics of the Goods, and the substituted materials or components are of a quality equal or superior to those originally specified;

9.1.7 for any damage caused as a result of the Goods being improperly installed or connected;

9.1.8 for any storage of the Goods have not been complied with in all respects;

9.1.9 in the event that the Customer fails to comply with the claims notification process set out in condition 8.

9.2 Any Goods which have been returned (as a credit is to be given) or replaced in accordance with condition 9.1 will belong to the Company. Any repaired or replacement Goods will be liable to repair or replacement under the terms specified in condition 9.1 for the unexpired portion of the 12 month period from the original date of delivery of the replaced Goods.

9.3 The delivery of any returned, repaired or replacement Goods in accordance with condition 9.1 shall be at the Customer's premises or other delivery point specified for the original Goods.

9.4 Subject to this condition 9, all warranties, conditions and other terms implied by law (whether by statute, common law or otherwise) are excluded from the Contract.

EXTENT OF LIABILITY

10.1 Nothing in this Contract shall limit or exclude the Company's liability for:

10.1.1 death or personal injury caused by its negligence, or the negligence of its employees, agents or subcontractors (as applicable);

10.1.2 fraud or fraudulent misrepresentation;

10.1.3 breach of the terms implied by section 12 of the Sale of Goods Act 1979;

10.1.4 any matter in respect of which it would be unlawful for the Company to exclude or restrict liability.

10.2 Subject to condition 10.1, the Company shall have no liability to the Customer whether in contract, tort (including negligence), breach of statutory duty, or otherwise for any injury, death, or indirect or consequential loss (all two of which terms include, without limitation, pure economic loss, loss of profits, loss of business, depletion of goodwill and like loss)

howsoever caused in connection with the performance or purported performance of or failure to perform the Contract.

10.3 Where the Company is liable in accordance with condition 9 in respect of only some or part of the Goods the Contract shall remain in full force and respect of the other or other parts of the Goods and no set off or other claim shall be made by the customer against or in respect of such other or other parts of the Goods.

10.4 The Customer shall have no claim against the Company for any defect arising from any design or specification provided or made by the Customer or if any adjustments alterations or other work has been done to the Goods by any person other than the Company.

10.5 Subject to condition 10.1, in no circumstances shall the total liability of the Company to the Customer under this Contract whether in contract, tort (including negligence), breach of statutory duty, or otherwise exceed the invoice value of the Goods.

GENERAL

11.1 The Contract is between the Company and the Customer as principals and shall not be assignable to the Customer without the express written consent of the Company.

11.2 The Company shall have a lien on all the Customer's property in the Company's possession for all sums due at any time from the Customer and shall be entitled to use sell or dispose of that property as agent for and at the expense of the Customer and apply the proceeds in and towards the payment of such sums on 28 days' notice in writing to the Customer. Upon accounting to the Customer for any balance remaining after payment of any sums due to the Company and the costs of sale or disposal the company shall be discharged of any liability in respect of the Customer's property.

11.3 The Company may at its absolute discretion suspend or terminate the supply of any Goods if the Customer fails to make any payment when and as due or otherwise defaults in any of its obligations under the Contract or any other agreement with the Company or becomes insolvent, has a receiver appointed of its business or is compulsorily or voluntarily wound up or the Company bona fide believes that any of those events may occur and in case of termination shall be entitled to forfeit any deposit paid by the Customer.

11.4 The Company reserves the right to carry out changes in manufacture of the Goods at any time without notice to distributors or other purchasers of its products.

11.5 The Company may at any time assign, transfer, charge, subcontract or deal in any other manner with all or any of its rights or obligations under the Contract. The Customer may not assign, transfer, charge, subcontract or deal in any other manner with all or any of its rights or obligations under the Contract without the prior written consent of the Company

11.6 The parties do not intend that any term of the Contract will be enforceable under the Contracts (Rights of Third Parties) Act 1999 by any person.

11.7 If any term of the Contract is found by any court or body or authority of competent jurisdiction to be illegal, unlawful, void or unenforceable, such term will be deemed to be severed from the Contract and this will not affect the remainder of the Contract which will continue in full force and effect.

11.8 A delay in exercising or failure to exercise a right or remedy under or in connection with the Contract will not constitute a waiver of, or prevent or restrict future exercise of, that or any other right or remedy, nor will the single or partial exercise of a right or remedy prevent or restrict the further exercise of that or any other right or remedy. A waiver of any right, remedy, breach or default will only be valid if it is in writing and signed by the party giving it and only in the circumstances and for the purpose for which it was given and will not constitute a waiver of any other right, remedy, breach or default.

11.9 The Contract constitutes the entire agreement between the parties. The Customer acknowledges that it has not relied on any statement, promise or representation made or given by or on behalf of the Company which is not set out in the Contract

11.10 The Customer will keep confidential any Confidential Information that it receives from the Company and will not use such Confidential Information for any purpose other than to perform its obligations under the Contract.

CANCELLATION

12. Orders for Goods may be cancelled by the Customer by written notice to the Company at any time prior to the order for such Goods being accepted by the Company in accordance with condition 3.1 but if a cancellation notice is received after the order for such Goods has been accepted by the Company in accordance with condition 3.1 then the order can only be cancelled at the Company's discretion and a packing and handling charge will be payable by the Customer.

FORCE MAJEURE

13. If a party obliged to perform the Contract or any obligation under it is prevented or restricted from doing so by reason of a Force Majeure Event the party so affected upon giving prompt notice to the other party shall be excused from performance to the extent of the prevention restriction or interference but the party so affected shall use its best efforts to avoid or remove such causes of non-performance and shall continue performance under the Contract with the utmost dispatch whenever such causes are removed or diminished.

LAW AND CONSTRUCTION

14.1 The Contract shall be governed by English Law and the Customer consents to the exclusive jurisdiction of the English Courts in all matters regarding the Contract except to the extent that the Company invokes the jurisdiction of the Courts of any other country

14.2 The headings of conditions are for convenience of reference only and shall not affect their interpretation.

NOTICES

15. Any Notice to be given under the Contract shall be in writing and telexed sent by facsimile transmission or forwarded by first class prepaid letter post to the receiving party at its business address as last notified in writing to the other party and shall be deemed to have been given on the date of the telex or facsimile transmission or on the day following that on which the notice was posted.

BLUE SEAL®



POWER • PERFORMANCE • RELIABILITY



PRODUCT PRICE LIST JUNE 2022

Blue Seal Limited,
Unit 67, Gravelly Business Park, Gravelly, Birmingham B24 8TQ

T: 0121-327-5575 | F: 0121-327-9711 | sales@blue-seal.co.uk | www.blue-seal.co.uk

In line with our policy to continually develop and improve our products, Blue Seal Limited reserves the right to change specifications without notice

